

Why choose Farrat Isomat IMCR?

Isomat is a high quality, easy to use and economical elastomeric isolation material. It has been specially designed by Farrat to provide excellent low frequency vibration, acoustic and shock isolation and has been used globally in industrial and structural applications. Isomat is produced in the UK by Farrat using high quality ISO6446 compliant chloroprene / neoprene compound.

Features

- Tested and approved to ISO6446 and BS6177.
- High resilience and low damping characteristics.
- Excellent shock absorption characteristics.
- Excellent ozone, oil and general chemical resistance.
- Low level of creep.
- Long lifetime (in excess of 60 years).
- Fire / flame resistance.
- Can be supplies as sheets or cut to size pads and strips (including holes and slots if required) according to the customer's requirements.

Applications

Farrat Isomat has been used in a wide range of applications such as;

- Acoustic floating floor systems.
- Acoustic structural bearings, steelwork isolators and steel to precast concrete connections within building structures.
- Acoustic strip bearings for walls.
- Isolated foundations for sensitive or high impact machinery.
- Plain pad isolators for machinery and plant equipment.
- Inertia base plinth isolation for plant equipment.

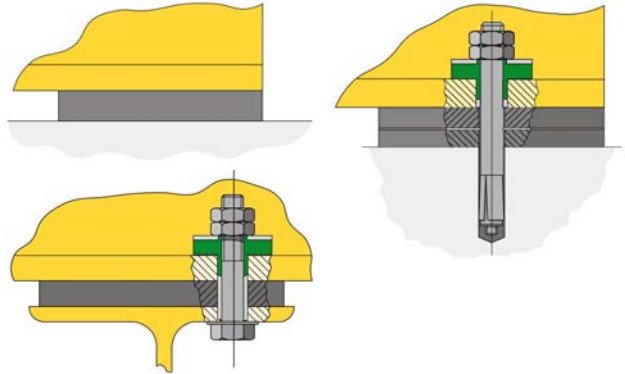

Where bolt through connections are required, Farrat Anti-vibration (AW) washers & bushes should be incorporated in order to allow free movement of the pad and to ensure that the bolt does not transmit vibration across the connection.

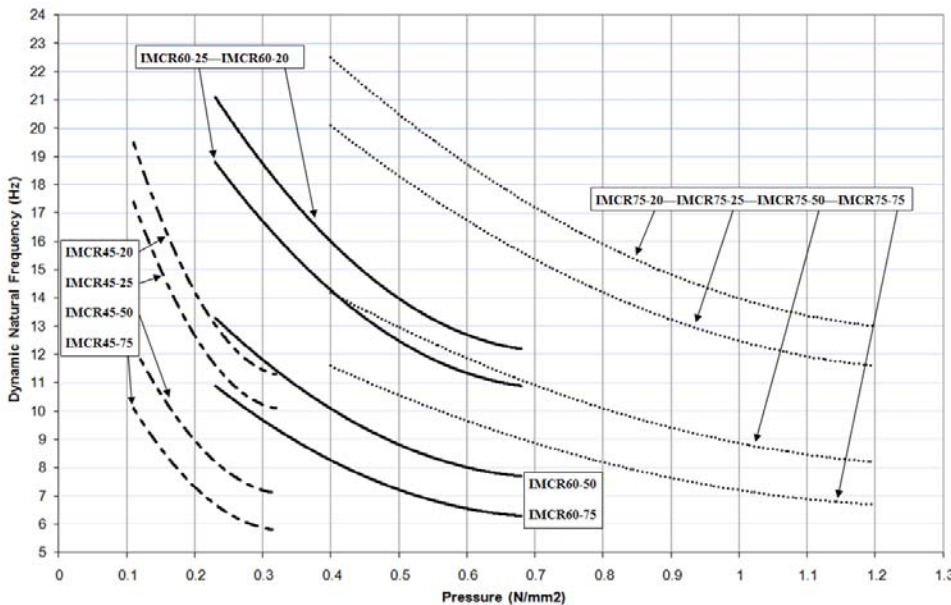

In some applications such as high load connections Isomat may not be the most appropriate material. Other Farrat materials may be more suitable.

Farrat are happy to advise and provide technical calculations to specify the most appropriate material.

Isomat IMCR45
High Performance vibration isolation material



AVM - Isomat IMCR45 - 10a

Isomat IMCR45 is made from high quality 45 shore neoprene rubber and will provide the best vibration isolation performance out of the Isomat range due to its minimal damping.



Characteristics	Unit	Test Standard	IMCR45
Colour			Black
Thicknesses	mm		20, 25, 37, 50, 75
Hardness (IRHD) ±5		BS ISO 48	45
Static Compression Modulus	N/mm ² / Mpa		2
Ratio Dyn to Static Modulus			1.55
Maximum Static Pressure	N/mm ² / Mpa		0.33
Maximum Overload Pressure	N/mm ² / Mpa		0.8
Maximum Residual Compression	%	EN ISO 1856	2
Creep			Minimal
Tensile stress at break	N/mm ² / Mpa	BS ISO 37	16
Elongation at break	%	BS ISO 37	625
Low Temperature Resistance		BS ISO 6446 & BS6177	Pass
Ozone Resistance		BS ISO 1431-1	Pass
Operating Temperatures*	°C		-30 to +120
Properties subject to change outside range	°C		-10 to +80
Flamability		DIN 4102 EN ISO 11925-2	B2 B, C, D
Operational life (subject to environment)	years		65+
Standard Sheet Size	mm		1000 x 500

Performance curves for Isomat pads 150x150mm and above, smaller pads have lower loading pressures. Performance characteristics of smaller pads are outlined in separate datasheets.

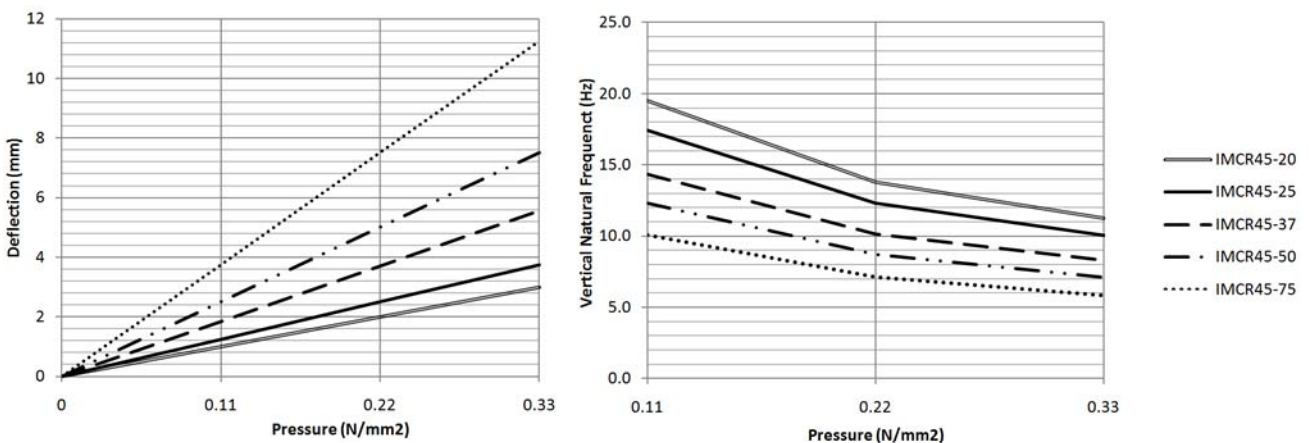

www.farrat.com

Farrat.com

Farrat Isolevel Ltd. Balmoral Road, Altrincham,
Cheshire WA15 8HJ. England GB
Tel: +44 (0) 161 924 1600
Fax: +44 (0) 161 924 1616 email: sales@farrat.com

Information in this brochure is for guidance only and in the interests of product development may change.

Isomat IMCR60

High Performance vibration isolation material



AVM - Isomat IMCR60 - 10a

Isomat IMCR60 is made from high quality 60 shore neoprene rubber and will provide an excellent balance of load bearings capacity and vibration isolation performance.



Characteristics	Unit	Test Standard	IMCR60
Colour			Black
Thicknesses	mm		20, 25, 37, 50, 75
Hardness (IRHD) ±5		BS ISO 48	60
Static Compression Modulus	N/mm ² / Mpa		3
Ratio Dyn to Static Modulus			1.65
Maximum Static Pressure	N/mm ² / Mpa		0.68
Maximum Overload Pressure	N/mm ² / Mpa		1.6
Maximum Residual Compression	%	EN ISO 1856	<0.2
Creep			Minimal
Tensile stress at break	N/mm ² / Mpa	BS ISO 37	14.8
Elongation at break	%	BS ISO 37	390
Low Temperature Resistance		BS ISO 6446 & BS6177	Pass
Ozone Resistance		BS ISO 1431-1	Pass
Operating Temperatures*	°C		-30 to +120
Properties subject to change outside range	°C		-10 to +80
Flamability		DIN 4102 EN ISO 11925-2	B2 B, C, D
Operational life (subject to environment)	years		65+
Standard Sheet Size	mm		1000 x 500

Performance curves for Isomat pads 150x150mm and above, smaller pads have lower loading pressures. Performance characteristics of smaller pads are outlined in separate datasheets.

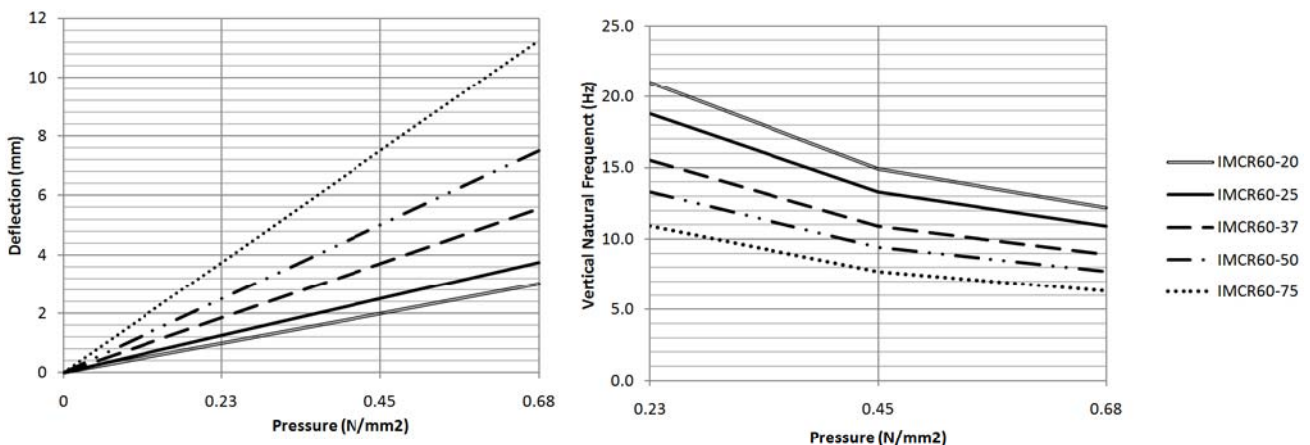

www.farrat.com

Farrat.com

Farrat Isolevel Ltd. Balmoral Road, Altrincham,
Cheshire WA15 8HJ. England GB
Tel: +44 (0) 161 924 1600
Fax: +44 (0) 161 924 1616 email: sales@farrat.com

Information in this brochure is for guidance only and in the interests of product development may change.

Isomat IMCR75

High Performance vibration isolation material



AVM - Isomat IMCR75 - 10a

Isomat IMCR75 is made from high quality 75 shore neoprene rubber and will provide high load bearing capacity, good shock absorption due to its higher level of damping and medium vibration isolation performance.



Characteristics	Unit	Test Standard	IMCR75
Colour			Black
Thicknesses	mm		20, 25, 37, 50, 75
Hardness (IRHD) ±5		BS ISO 48	75
Static Compression Modulus	N/mm ² / Mpa		6
Ratio Dyn to Static Modulus			2
Maximum Static Pressure	N/mm ² / Mpa		1.2
Maximum Overload Pressure	N/mm ² / Mpa		1.76
Maximum Residual Compression	%	EN ISO 1856	3
Creep			Minimal
Tensile stress at break	N/mm ² / Mpa	BS ISO 37	14.3
Elongation at break	%	BS ISO 37	280
Low Temperature Resistance		BS ISO 6446 & BS6177	Pass
Ozone Resistance		BS ISO 1431-1	Pass
Operating Temperatures*	°C		-30 to +120
Properties subject to change outside range	°C		-10 to +80
Flamability		DIN 4102 EN ISO 11925-2	B2 B, C, D
Operational life (subject to environment)	years		65+
Standard Sheet Size	mm		1000 x 500

Performance curves for Isomat pads 150x150mm and above, smaller pads have lower loading pressures. Performance characteristics of smaller pads are outlined in separate datasheets.

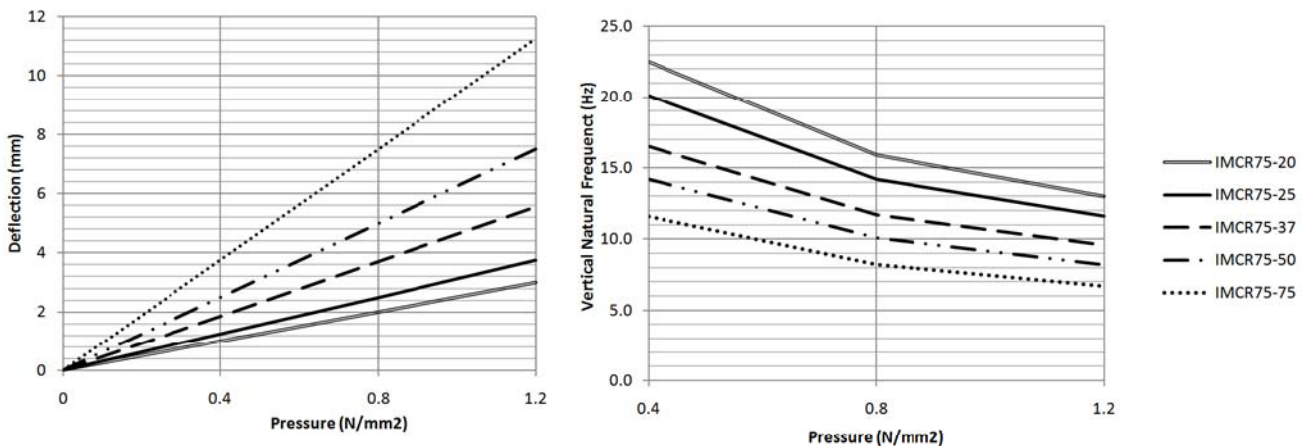

www.farrat.com

Farrat.com

Farrat Isolevel Ltd. Balmoral Road, Altrincham,
Cheshire WA15 8HJ. England GB
Tel: +44 (0) 161 924 1600
Fax: +44 (0) 161 924 1616 email: sales@farrat.com

Information in this brochure is for guidance only and in the interests of product development may change.