

AWTH Top Hat Acoustic Washers

Integrated acoustic washer and sleeve



AVW-AWTH Top Hat Acoustic Washers-10a

Why choose AWTH Acoustic Washers?

Farrat AWTH anti vibration top hat washers are the best way to isolate bolt through connections by providing a complete separation of the bolt and the isolated structure.

Features

- Used in conjunction with acoustic / anti vibration pads to provide a high degree of vibration isolation by providing a resilient connection where bolt through fixings are necessary for stability and security.
- If an acoustic washer is omitted then the anti vibration pad will be bypassed by the fixing bolt and will therefore offer limited isolation and the vibration can be transmitted through the fixing bolt.
- Manufactured for durability, performance and ease of on site installation by vulcanising zinc plated washer to a Chloroprene (Neoprene) acoustic washer and sleeve (bush).
- Good oil, chemical and fire resistance.
- Operating temperature range from -10 to +90 °C.
- Fire rating / building material class: B2

Applications

Any bolt through connection which requires isolation such as:

- Steelwork Isolation in building structures
- Machine tool holding down bolts

Important Note

Holes in steelwork need to be oversized to accommodate the isolation bush, see column J of the table below.

If oversized holes are not possible then we recommend using AWR washers which do not have an isolation sleeve.

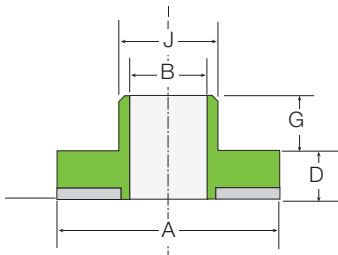
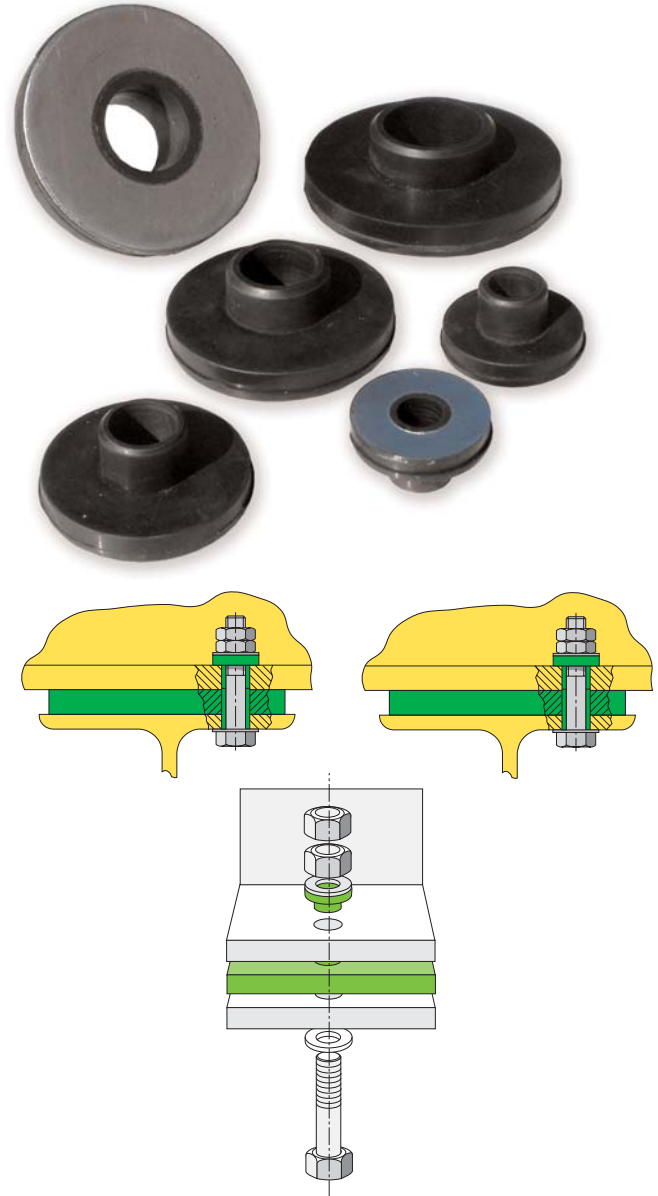

					J Min Hole diameter required in steelwork	Normal Applications			Maximum Loads		
	A	B	D	G		Torque* Normal	Number of turns for metric Standard threads	Static Deflection	Torque* Max	Number of turns for diameter Standard threads	Static Deflection
AWTH Washers	mm	mm	mm	mm	mm	Nm	-	mm	Nm		mm
AWTH 08	26	8.5	5.6	10	12.5	2.5	1/3	0.4	4	1/2	0.6
AWTH 10	30	10.5	6.0	10	14.5	5.5	1/4	0.4	8	1/3	0.6
AWTH 12	40	13.0	6.5	10	16.5	18	1/4	0.4	27	1/3	0.6
AWTH 16	50	17.0	8.0	10	22.5	22	1/4	0.5	33	1/3	0.8
AWTH 20	61	21.0	9.0	10	27.0	52	1/4	0.6	79	1/3	0.9
AWTH 24	65	25.0	10.0	10	31.0	56	1/4	0.6	85	1/3	0.9

* Tightening torques relate to dry, unplated, metric coarse threads.

AWTH Top Hat Acoustic Washers

www.farrat.com



Farrat Isolevel Ltd. Balmoral Road, Altrincham, Cheshire WA15 8HJ. England GB

Tel: +44 (0) 161 924 1600

Fax: +44 (0) 161 924 1616 email: sales@farrat.com