

FSL Coil Spring Isolation System for structures and sensitive equipment.

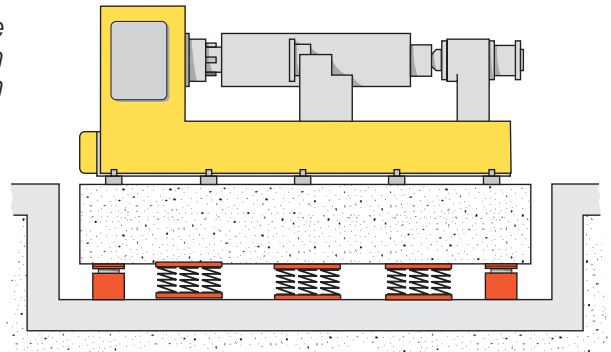

Precision Roll Grinding Machine on FSL Coil Spring Isolator with FV Damper Isolated Foundation System.



Coil Spring and Damper Systems



FSL Coil Spring Isolators



FSLV Coil Spring and Viscous Damper Isolators



FV Viscous Dampers

Why choose Farrat FSL Coil Spring Isolation systems?

FSL Coil Spring Isolation systems are used to provide both active and passive vibration isolation with natural frequencies down to 3Hz to isolate disturbing frequencies down to 6Hz.

Applications

- Building Structures
- Hospitals
- Roll grinding machines
- Power generation equipment (compressors, pumps, fans, gas and steam turbines, condensers)
- Crushing, milling and shredding equipment
- Oil and gas offshore platforms

Where a system is likely to go pass through or near resonance and excessive movement is a concern it is recommended that FV Viscous Dampers are used in conjunction with the FSL springs. This combination of FSL Coil Spring Isolators and FV Viscous Dampers also provides excellent shock absorption.

Active Shock and Vibration Isolation involves isolation of a dynamic system to reduce the effects of vibration and shock on nearby plant, machinery, people and building structures. Usually FSL + FV

Passive Shock and Vibration Isolation involves the protection of sensitive structures or equipment to protect them from the effects of vibration and shock caused by nearby plant, machinery, vehicles, people etc. Usually FSL only

Shock Isolation involves the isolators storing the kinetic energy of the shock through isolator deflection and subsequent release in a smoother form over a longer period with lower overall amplitudes. FSL + FV



Construction

FSL Coil Spring Isolators are constructed from heavy duty helical springs to BS 1726-1:2002 encased in heavy duty steel housings. They can be supplied as freestanding units with an elastomeric pad top and bottom to attenuate high frequency vibrations and provide good seating to contact surfaces. Bolt-on or grouted-in units as per the customers' requirements are also available to special order. FSL Coil Spring Isolators are normally supplied pre-compressed to minimise differential deflections during construction of supported masses.

Product Specifications

The standard FSL Coil Spring Isolators are available in three sizes. The size required will depend upon the mass to be supported and the specified system natural frequency. Farrat can design bespoke FSL spring units to match exact load bearing and performance requirements. FSL Coil Spring Isolators can be used either on their own or in a variety of combinations and support arrangements.

Farrat will design the isolation system to meet a customer's specific technical requirements and provide construction drawings, installation instructions and optional installation supervision with all FSL Coil Springs.

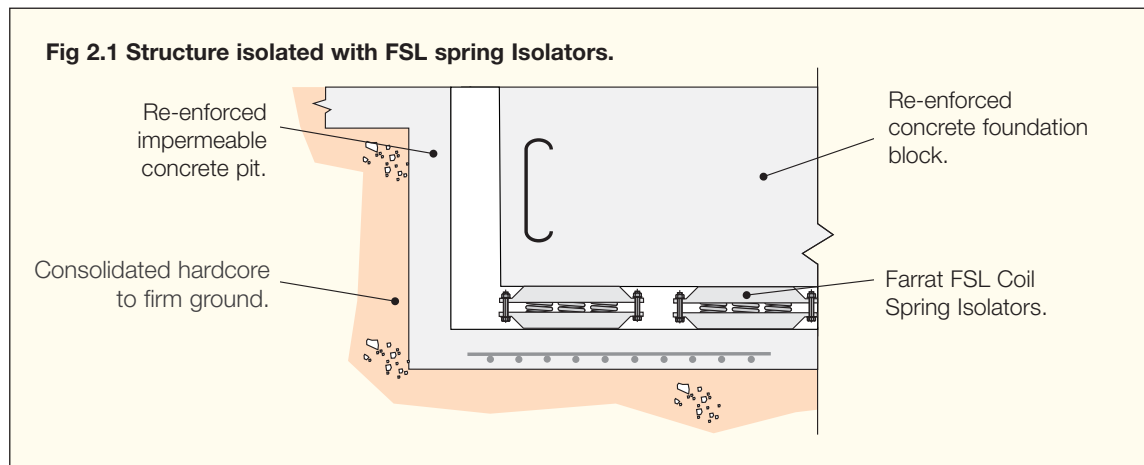

FSL Coil Spring Units (Standard variants*)										
Product	Length mm	Width mm	Spring rate	Load Per Unit at		Natural Frequency at		Isolator Height at		
			Max. load kN/mm	Max. load kN	Min. load kN	Max. load Hz	Min. load Hz	Max. load mm	Min. load mm	Free mm
FSL 1-4	500	305	3.4	85	28	3.2	5.5	140	157	165
FSL 1-6	550	305	5.1	128	42	3.2	5.5	140	157	165
FSL 1-8	725	305	6.8	170	56	3.2	5.5	140	157	165

*FSL spring units can be designed to match exact load bearing and performance requirements. Please contact Farrat for more information.

Why Farrat FV Viscous Dampers?

Farrat FV Viscous dampers can be used in combination with FSL Coil Spring Isolators (not on their own) to limit the potential motion of the FSL Coil Spring Isolators under shock loads or if the system is likely to pass through resonant frequencies (disturbing frequency is the same as the isolation system's natural frequency). In such instances excessive movement amplitudes can occur if no damping is incorporated. FV Viscous Dampers limit this movement by converting the kinetic energy of the movement into heat within the viscous fluid of the damper.

Applications

- Building Structures
- Hospitals
- Roll grinding machines
- Power generation equipment (compressors, pumps, fans, gas and steam turbines, condensers)
- Crushing, milling and shredding equipment
- Oil and gas offshore platforms

Construction

FV Viscous Dampers are constructed from fabricated steel upper and lower steel housings to a special high performance Farrat design with suitably sized 'cast in' sockets or fixing screws to the customer's requirements. Special viscous damping fluid is supplied in separate containers.

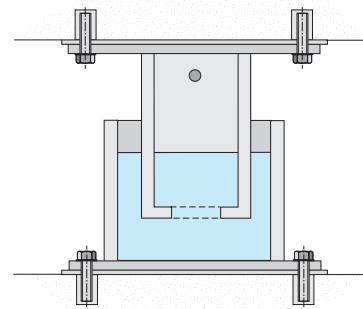

Fig 3.1

Product Specifications

The standard FV Viscous Damper units are available in three sizes. The damper size and damping fluid will depend upon the mass being supported and the amount of damping required.

Farrat will design the isolation system to meet a customer's specific technical requirements and provide construction drawings, installation instructions and optional installation supervision with all FSL Coil Spring and FV Viscous Damper units.

Fig 3.2 FV viscous dampers used to provide damping to an FSL isolation system.

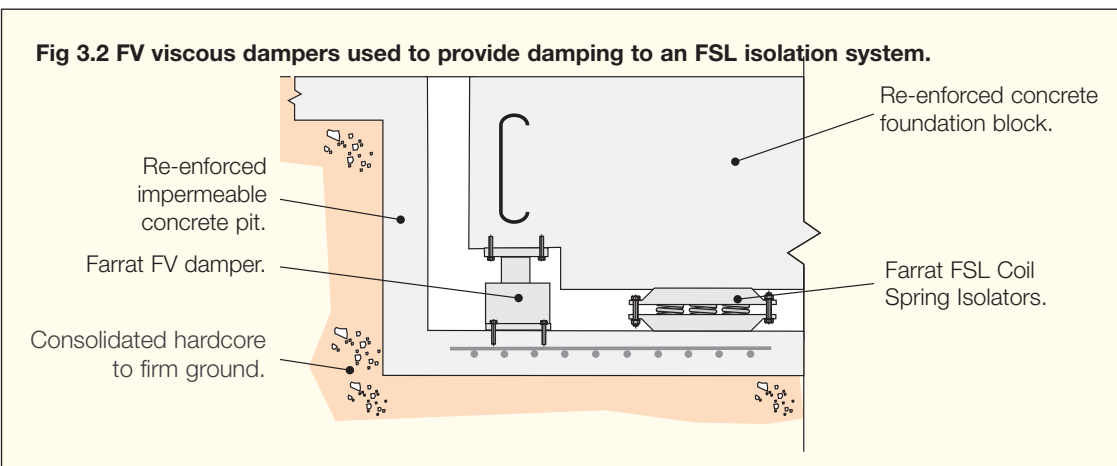

Product	Width	Length	Working Height	Damping Ratio
	mm	mm	mm	C/Cc
FV 1	250	250	300	0.2-0.5
FV 2	330	330	400	0.2-0.5
FV 3	406	406	450	0.2-0.5

Why choose Farrat FSLV Coil Spring and Viscous Damper Isolators?

FSLV Coil Spring and Viscous Damper Isolators combine an FV viscous damper into a modified FSL Coil Spring Isolator to provide a compact integrated unit. They should be used where there is a risk that the isolated system will pass through resonance or if excessive movement is a concern such as in shock absorption. They can be used to provide both active and passive vibration isolation with natural frequencies down to 3Hz to isolate disturbing frequencies down to 6Hz.

Applications

- Building Structures
- Hospitals
- Roll grinding machines
- Power generation equipment (compressors, pumps, fans, gas and steam turbines, condensers)
- Crushing, milling and shredding equipment
- Oil and gas offshore platforms

Active Shock and Vibration Isolation involves isolation of a dynamic system to reduce the effects of vibration and shock on nearby machinery, people and building structures.

Passive Shock and Vibration Isolation involves the protection of sensitive structures or equipment to protect them from the effects of vibration and shock caused by nearby plant, machinery, vehicles, people etc.

Shock Isolation involves the isolators storing the energy of the shock through isolator deflection and subsequent release in a smoother form over a longer period with lower overall amplitude. FSLV Viscous Dampers limit this movement by converting the kinetic energy of the movement into heat within the viscous fluid of the damper.

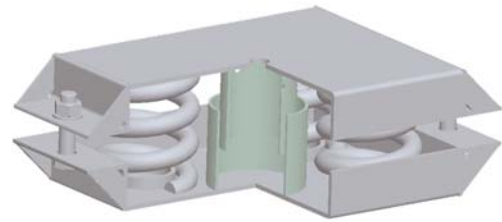

Construction

FSLV Coil Spring and Viscous Damper Isolators are constructed from heavy duty helical springs to BS 1726-1:2002 encased in heavy duty steel housings. They can be supplied as freestanding units with an elastomeric pad top and bottom to attenuate high frequency vibrations and provide good seating to contact surfaces. Bolt on or grouted in units as per the customers' requirements are also available to special order. FSLV units are normally supplied pre-compressed to minimise differential deflections during construction of supported masses. Special viscous damping fluid is supplied in separate containers.

Product Specifications

The standard FSLV Coil Spring and Viscous Damper Isolators are available in three sizes. The size required will depend upon the mass to be supported, the specified system natural frequency and the amount of damping required. Farrat can design bespoke FSLV units to match exact load bearing and performance requirements. FSLV Coil Spring and Viscous Damper units can be employed in a variety of combinations and support arrangements, Farrat will design the isolation system to meet a customer's specific technical requirements and provide construction drawings, installation instructions and optional installation supervision with all FSLV units.

Fig 4.1 FSLV Coil Spring and Viscous Damper units used to isolate structures and industrial equipment.

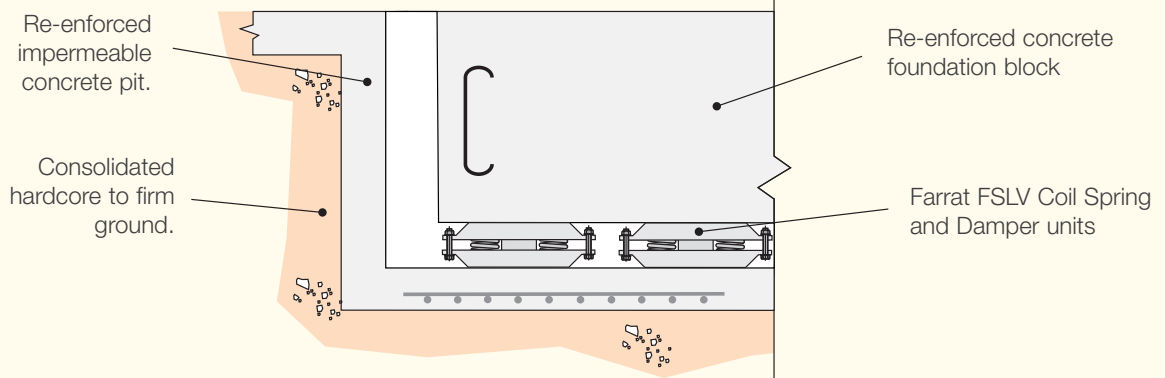

FSLV Coil Spring and Viscous Damper Units (Standard variants*)												
Product	Length mm	Width mm	Spring rate kN/mm	Load Per Unit at		Natural Frequency at			Isolator Height at			Damping Ratio C/Cc
				Max load kN	Min load kN	Min load Hz.	Max load Hz.	Min load kN	Max kN	Free kN		
FSLV 1-4	500	305	3.4	85	28	3.2	5.5	140	157	165	0.15	
FSLV 1-6	720	305	5.1	127	42	3.2	5.5	140	157	165	0.15	
FSLV 1-8	850	305	6.8	170	56	3.2	5.5	140	157	165	0.15	

*FSL spring units can be designed to match exact load bearing and performance requirements. Please contact Farrat for more information.