

# Farrat Isolevel

Foundation Shock and Vibration Isolation Systems for Structures, Machinery and Equipment

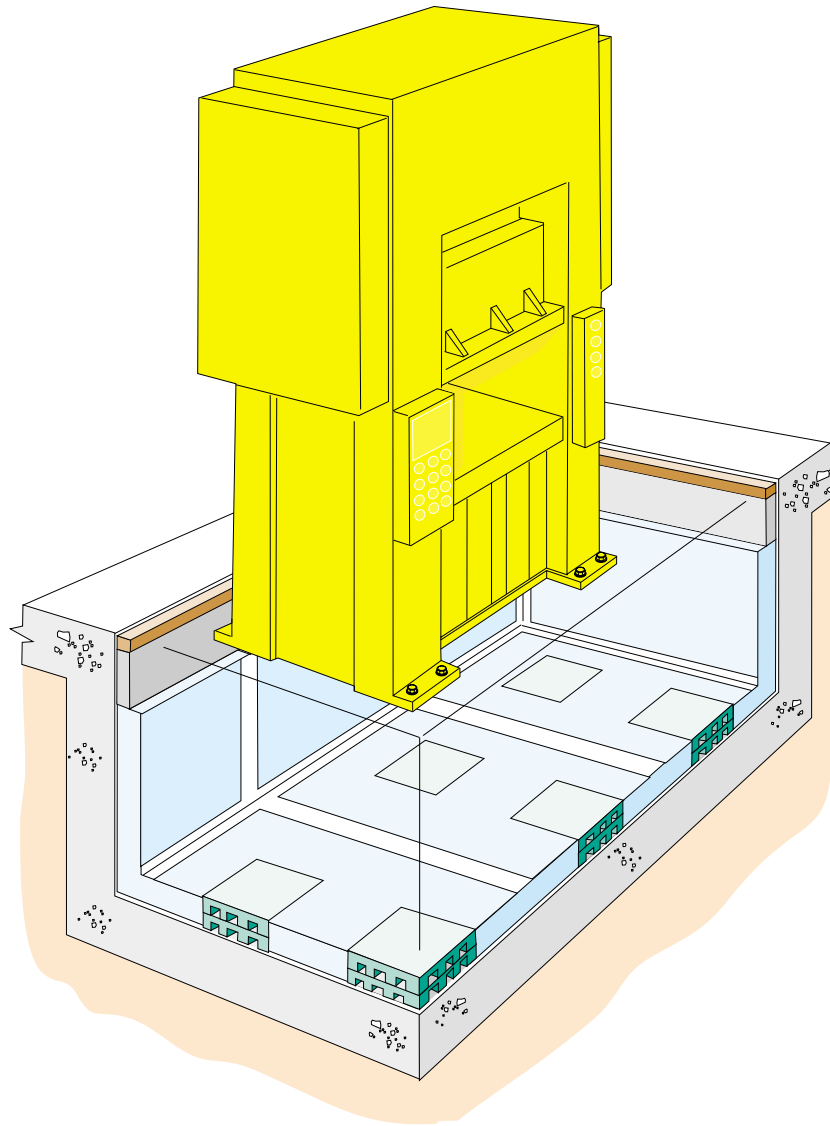

www.farrat.com

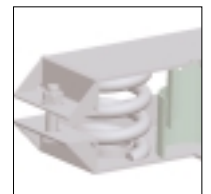
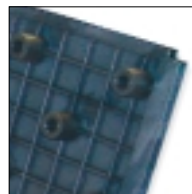
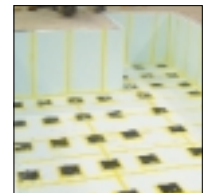
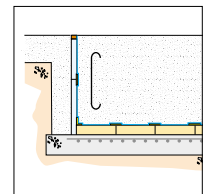
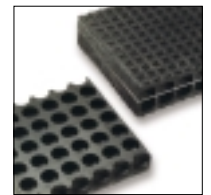

## Reasons for using isolated foundations

- Increasing machine frame stiffness to maintain alignment during changes in applied static and dynamic loads.
- Minimising changes in level due to alterations in static load distribution
- Increasing inertia mass of the machine and reducing vibration through mass damping.
- Lowering the centre of gravity to improve stability.
- Distributing static and dynamic loads over a greater ground area.
- Isolating low frequency of shock and vibration using more elastic vibration isolators than could be used between machine and foundation.
- Low frequency disturbing vibration requires low frequency, high deflection vibration isolators. On machinery requiring low operating motion amplitudes an isolated foundation is essential if low frequency vibration isolation is required.

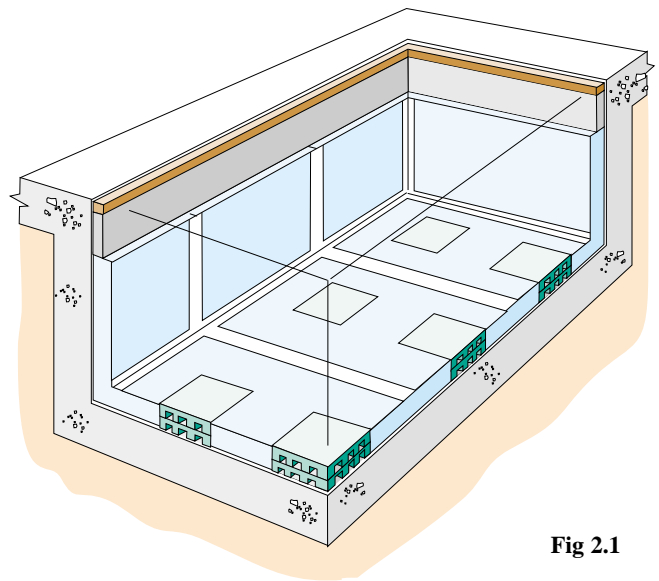

Fig 2.1

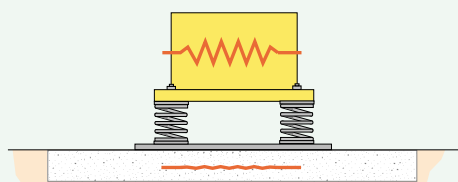

Fig 2.2

Machine on isolators on the floor, no foundation

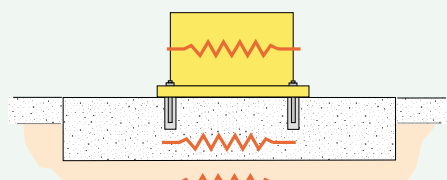

Fig 2.3

Machine on foundation, no isolation

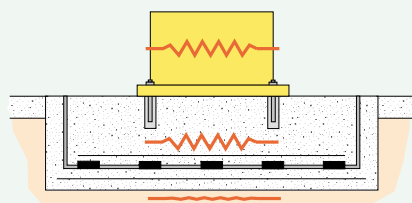

Fig 2.4

Machine on isolated foundation, active shock and vibration

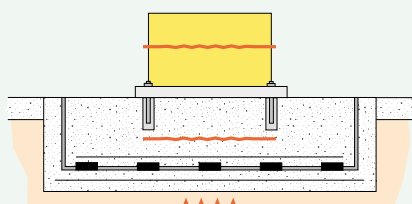

Fig 2.5

Machine on isolated foundation, passive shock and vibration

### Vibration Control/Isolation

Vibration Control involves the correct use of a resilient mounting or material in order to provide a degree of isolation between a machine and its supporting structure. A condition should be achieved where the amount of vibration transmitted from, or to, the machine is at an acceptable level.

To achieve efficient vibration isolation it is necessary to use a resilient support with sufficient elasticity so that the natural frequency  $f_n$  of the isolated machine is substantially lower than the disturbing frequency  $f_e$  of vibration. The ratio  $f_e/f_n$  should be greater than 1.4 and ideally greater than 2 to 3 in order to achieve a significant level of vibration isolation

Damping provides energy dissipation in a vibrating system. It is essential to control the potential high levels of transient vibration and shock, particularly if the system is excited at, or near, to its resonant frequency.

### Active Shock and Vibration Isolation

A foundation block for a dynamic machine should be isolated in order to reduce the effects of vibration and shock on nearby machines, people and the building structure. Controlling the source of a structural disturbance is known as active isolation.

**Applications include:** isolation of foundations for: power presses, pumps, drop hammers, forging machines, metal forming and cutting machines, compressors, gensets, engines and test rigs, printing machines and rolling roads.

### Passive Shock and Vibration Isolation

When it is not possible to prevent or sufficiently lower the transmission of shock and vibration from the source a resiliently supported foundation block can be used for the passive isolation of sensitive equipment.

**Applications include:** isolated foundations for: machining centres, grinding machines, measuring and inspection equipment, laser cutters and microscopes.

Sources of vibration in rotating machines	
Source	Disturbing Frequency <i>fe</i> Hz
Primary out of balance	1 x rpm x 0.0167
Secondary out of balance	2 x rpm x 0.0167
Shaft misalignment	2 x rpm x 0.0167
Bent Shaft	& 2 x rpm x 0.0167
Gears(N=number of teeth)	N x rpm x 0.0167
Drive Belts (N=belt rpm)	N,2N,3N,4N x 0.0167
Aerodynamic or hydraulic forces	(N=blades on rotor) N x rpm x 0.0167
Electrical (N=synchronous frequency)	N x rpm x 0.0167

Significant problems occur when the disturbing frequency *fe* is near to or coincident with the natural frequency of the supporting structure (floor, foundation or subsoil).

Typical support natural frequencies ( <i>fn</i> )			
Structures	Natural Frequency <i>fn</i> Hz	Isolator Frequency <i>fni</i> Hz	Isolator type
Suspended concrete floor	10-15	3-5	Helical, Air Springs
Ground Floor	12-34	6-8	Helical, Air Springs, Elastomeric
Soft Clay	12	6-8	Helical, Air Springs, Elastomeric
Medium Clay	15	6-8	Elastomeric Isolators
Stiff Clay	19	8-10	Elastomeric Isolators
Loose Fill	19	8-10	Elastomeric Isolators
Very dense mixed grain sand	24	10-12	Elastomeric Isolators
Limestone	30	10-12	Elastomeric Isolators
Hard Sandstone	34	10-12	Elastomeric Isolators

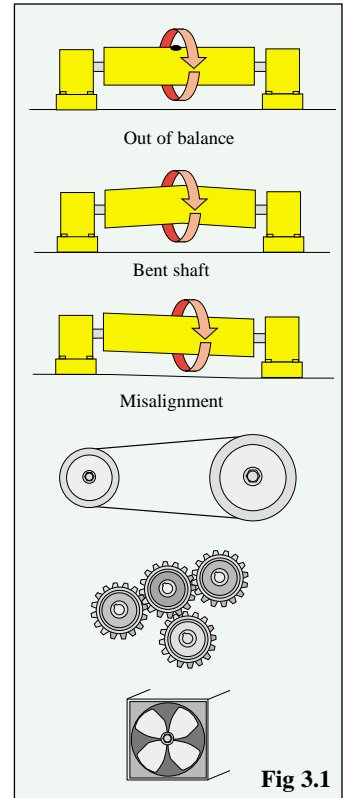

Fig 3.1

Theory of Vibration Isolation

Vibration Isolation

Vibration Isolation reduces the level of vibration transmitted to or from a machine, building or structure from another source.

The degree of isolation achieved depends on the ratio:

$$\frac{\text{Frequency of disturbing vibration}}{\text{Natural frequency of isolator}} = \frac{fe}{fn}$$

2: The level of isolator damping C/Cc

Referring to the diagram 3.07, the degree of isolation is given as Transmissibility (i.e. amount of vibration transmitted at a specific frequency *fe* as a fraction of the disturbing vibration at the same frequency *fe*).

Transmissibility:

- > 1 = Increased transmitted vibration
- = 1 = No vibration isolation
- < 1 = Vibration isolation

Transmissibility T can be read from diagram 3.2 or calculated as follows: If no damping present in isolators i.e. C/Cc = 0

Undamped systems:

$$\text{Transmissibility } T = \frac{1}{1 - R^2}$$

Damped systems:

$$\text{Transmissibility } T = \frac{1 + \frac{R^2}{Q^2}}{\sqrt{(1 - R^2)^2 + \frac{R^2}{Q^2}}}$$

$$R = \frac{fe}{fn} \quad Q = \frac{1}{2 C/Cc}$$

*fe* - disturbing frequency can be determined by measurement. The isolator natural frequency *fn* is given by:

$$fn = \frac{1}{2} \sqrt{\frac{Ktd}{M}} \text{ Hz}$$

**Ktd** = Sum of Isolator Dynamic Spring Constants (K<sub>1</sub>+K<sub>2</sub>+K<sub>3</sub>...) N/m

**M** = Supported system mass kg.

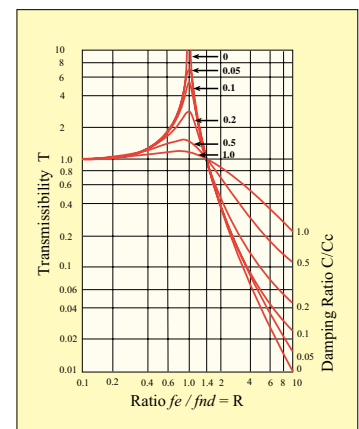

Fig 3.2

For natural rubber and coil spring isolators static and dynamic spring constants are the same.

Damping Factor	frequency ratio R <i>fe/fn</i>								
	C/Cc	1.5	2.0	2.5	3.0	3.5	4.0	4.5	5.0
0.05	20	66	80	87	91	93	94	94	95
0.10	19	64	79	85	89	91	93	93	94
0.15	17	62	76	83	87	90	91	91	93
0.20	16	59	74	81	85	87	89	89	91
0.30	12	52	67	75	80	83	85	85	87
Percentage Isolation Efficiency									



Farrat are certified to TUC UKQA ISO 9001/2000

## Reasons for isolating the effects of shock

Shock is created by impact of one mass against another e.g. during operation of power presses, forging machines, drop hammers etc. The shock impulse caused by the impact travels through the machine structure as a deflection wave. If the machine is rigidly connected to its foundation this deflection wave enters the foundation and the surroundings. The shock will generally cause the affected masses to vibrate at their own natural frequencies.

Reduction in shock severity by use of suitable isolators is achieved by the isolators storing the energy of the shock through isolator deflection and subsequent release in a smoother form over a longer period with lower overall amplitude.

A shock pulse may contain frequency components from 0-∞. It is therefore not possible to avoid resonance with the isolator/mass. If however the duration of the shock pulse is less than one half period of the isolation system resonance may not be serious.

**Figure 4.1**

Shows the output force (into the supporting floor) v time levels from a machine produced shock wave. In case 1 the machine under consideration is connected directly to the supporting floor. Case 2 typifies a machine installed on spring or elastomeric isolators in conjunction with a foundation block. It can be seen that the same amount of energy is transmitted in both instances. However in case 2 the energy is transmitted over a much larger time scale resulting in a substantially lower peak force. In reality the force transmitted will present itself as noise and structure borne vibration detectable by humans, it is therefore desirable in most instances to keep the peak value of transmitted force as low as possible by using on spring or elastomeric isolators between the machine and foundation or an elastically supported foundation block.

**Figure 4.2**

Shows a machine/structure that is rigidly connected to its foundation. The peak force into the structure is very high and of relatively short duration. Essentially all the force that occurs in the machine is transferred to the structure with the exception of that which is absorbed by the machine.

**Figure 4.3**

Illustrates the use of elastomeric or spring isolators between the machine and the supporting foundation. In this scenario with the correct isolator specification the peak force transmitted to the supporting foundation is significantly reduced resulting in reduced structure borne noise and transmitted vibration.

**Figure 4.4**

Illustrates the use of spring or elastomeric isolators supporting a foundation block. In this instance the peak force transmitted is reduced to virtually zero. The foundation block increases the system mass and reduces machine vibration and movement through mass damping.

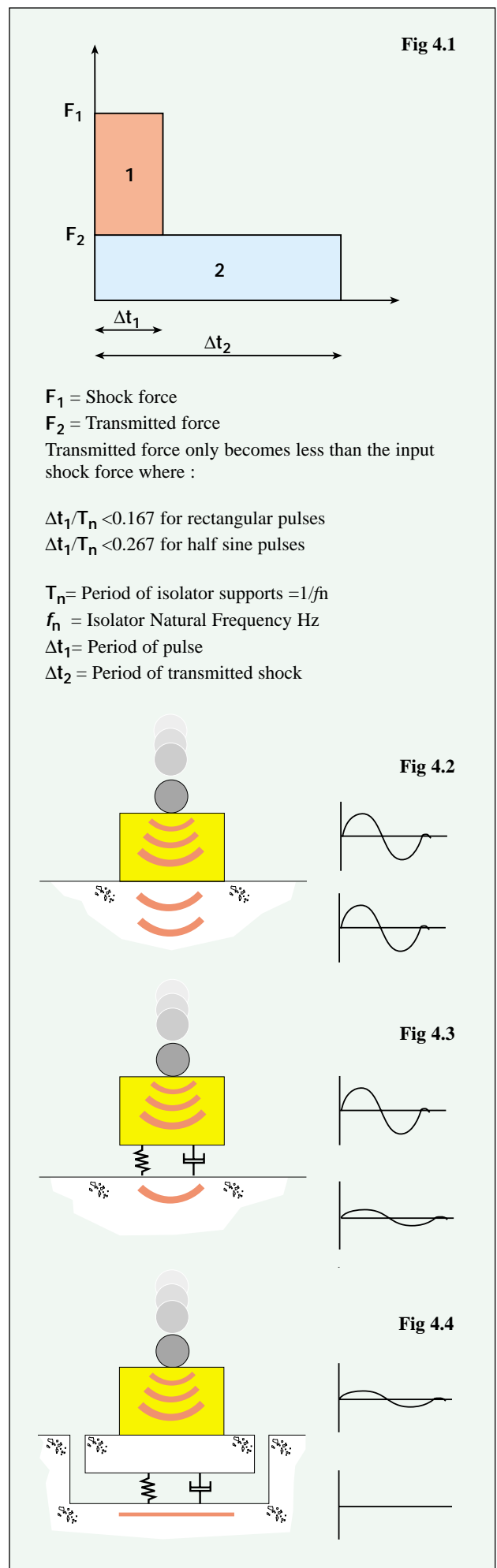

## High precision machine foundation vibration isolation

### Description

ISOMAT foundation isolators used in conjunction with **FVF** Farrat Base Void Filler and **LVI** and/or **ISF** Sidewall Vibration Isolation materials provide highly predictable performance characteristics over many years of service.

### ISOMAT is produced in three rubber types

- IM CR** Neoprene for high elasticity, moderate damping and self extinguishing properties. Conditional oil and chemical resistance
- IM NR** Natural Rubber for maximum elasticity and low damping (passive isolation) Poor oil and chemical resistance
- IM BR** Nitrile Rubber for excellent combination of elasticity, damping and excellent oil and chemical resistance.

**Working Temperature Range:** °C: -30 to +120

**Creep:** Very Low

**Building materials class:** B2

Complete chemical resistance tables available on request.  
Farrat would advise on most suitable **ISOMAT** grade for each application and provide full specification, predicted natural frequencies, damping, layout drawings and installation instructions.

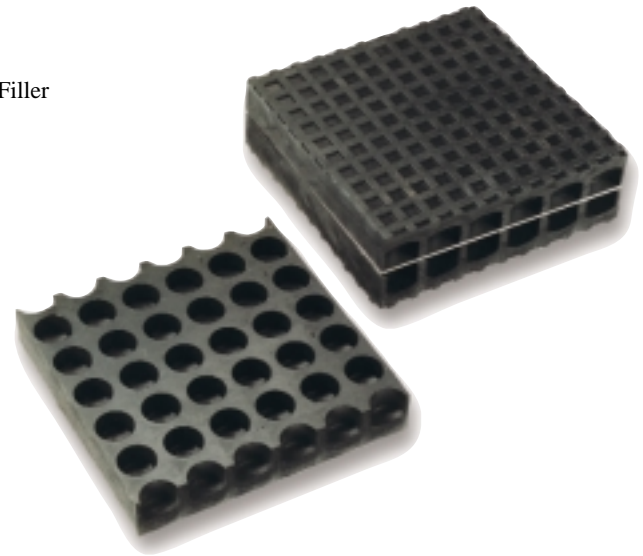

### Description of Diagram

- 1) Polymeric Sealant (eg Sikaflex Pro-3WF) or rubber sealing strip to prevent moisture ingress.
- 2) Top strip **Vidam VM** or **ISF**.
- 3) Reinforced concrete foundation block.
- 4) Sidewall Isolation: **ISF**, **FVF 15-50** or **LVI**.
- 5) **JLT** Joint line tape to all joints.
- 6) Reinforced impermeable concrete forming tank
- 7) Damp proof membrane **DPM**. Minimum 1000gsm.
- 8) **ISOMAT** Isolators.
- 9) Base void filler, **FVF-10-50**.
- 10) Consolidated hardcore to firm ground.

\* Reinforced concrete foundation blocks and associated structures to be designed by qualified consulting engineers and constructed by contractors of proven ability and experience.

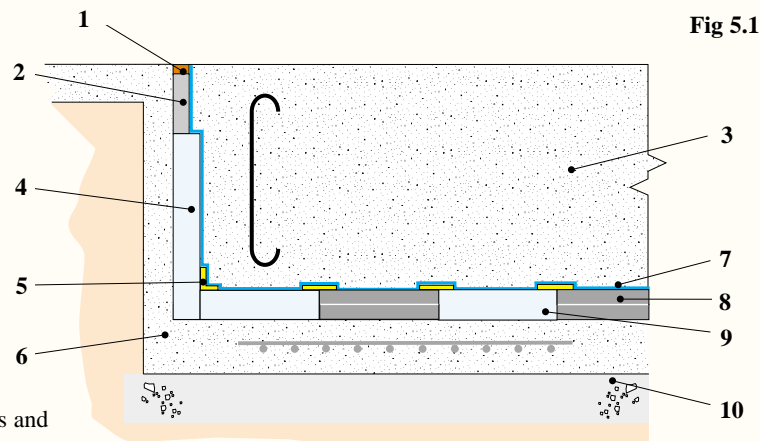

Fig 5.1

Isomat Foundation Shock and Vibration Isolators					ISOMAT Isolator Standard Sizes						Static Deflection Max load $\delta$	Damping C/Cc	Vert. Nat. Freq. Static $f_{sv}$	Vert. Nat. Freq. Dynamic $f_{dv}$
Product	Thick ness mm	Comp. Modulus Ec N/mm <sup>2</sup>	Isomat Length mm	Units mm	Other sizes available to suit application									
					150	200	250	325	500	500				
					Width mm	150	200	250	250	250	500			
Area m <sup>2</sup>	0.0225	0.04	0.0625	0.08125	0.125	0.25								
Max Pres. N/mm <sup>2</sup>	Maximum Static Loadings per ISOMAT						mm		Hz	Hz				
<b>ISOMAT IM CR 40</b>	25 50	2.7 2.7	0.35 0.35	kN	6	10	16	21	33	66	2.4 4.9	0.05 0.05	10.2 7.2	12.5 8.8
<b>ISOMAT IM NR 45</b>	25 50	3.7 3.7	0.45 0.45	kN	8	14	21	27	42	84	2.3 4.6	0.01 0.01	10.5 7.5	10.5 7.5
<b>ISOMAT IM BR 40</b>	25 50	3 3	0.4 0.4	kN	7	12.0	19	24	38	75	2.5 5.0	0.1 0.1	10.0 7.0	15.0 10.5
<b>ISOMAT IM BR 50</b>	25 50	3.7 3.7	0.5 0.5	kN	8	15	23	30	47	94	2.5 5.1	0.1 0.1	9.7 6.8	14.5 10.0
<b>ISOMAT IM BR 70</b>	25 50	6 6	1.2 1.2	kN	20	36	56	73	112	225	3.8 7.5	0.1 0.1	9.3 6.6	14.0 10.0

# Isolay ISL Full Area Carpet Vibration Isolation Foundation System

Isolay interlocking tiles, comprise of a hard ribbed rubber deck to the under side of which are moulded tuned rubber isolators. Rapid and simple installation.

**ISOLAY** is produced in three rubber types.

**ISL NR** Natural Rubber for maximum elasticity and low damping (passive isolation).

**ISL BR** Nitrile Rubber for excellent combination of elasticity, damping and oil and chemical resistance (active isolation).

**ISL CR** Neoprene for high elasticity, moderate damping and self extinguishing properties (active and passive isolation).

Farrat would advise on most suitable **ISOLAY ISL** grade for each application and provide full specification, predicted natural frequencies, damping ratio, layout drawings and installation instructions.

**Working Temperature Range:** °C: -30 to +120

**Building materials class:** B2

**Standard Sheet Size:** 500 x 500 mm and cut pads.

Farrat would supply mats to suit specific foundation bases.

Alternatively the client can cut tiles to suit areas where one or both dimensions are less than 500mm.

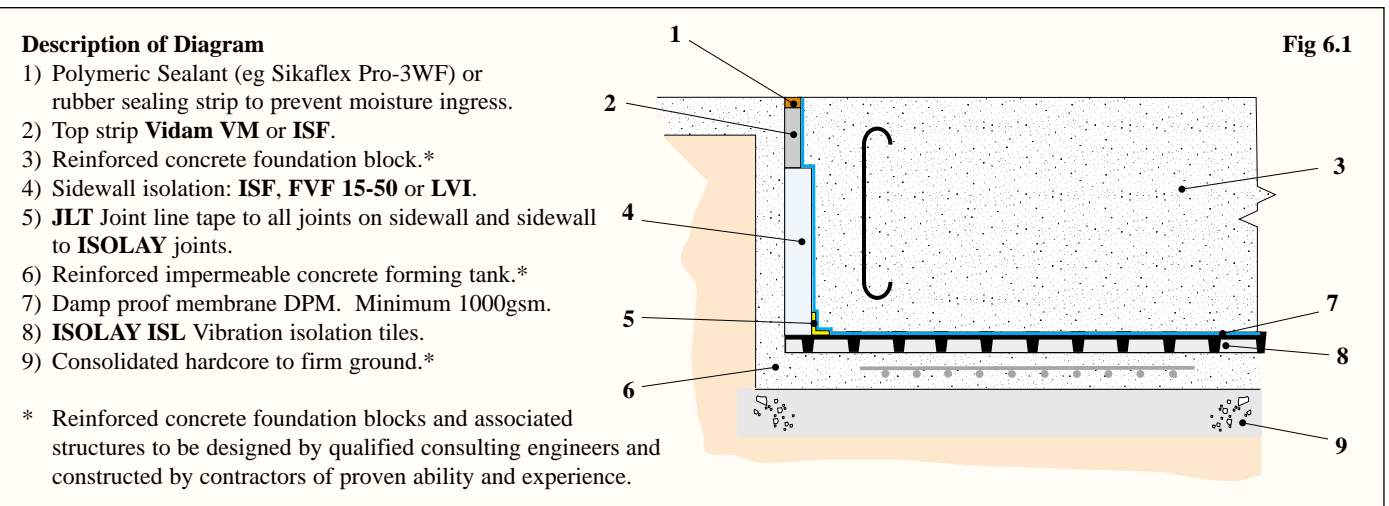
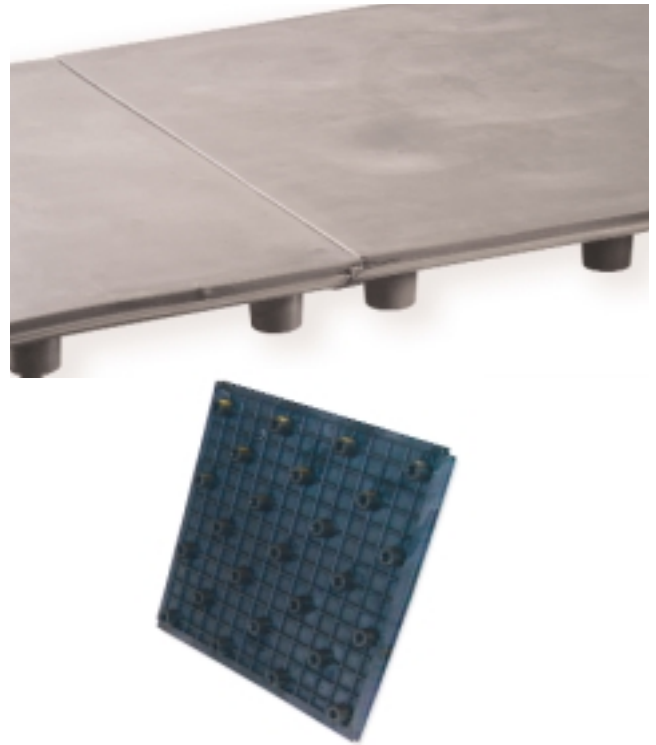

Select ISOLAY Grade		Damping C/Cc
<b>NR</b>	Passive isolation, low damping, high isolation efficiency	0.01
<b>BR</b>	Active isolation, excellent damping, very good oil and chemical resistance	0.10
<b>CR</b>	Active and passive isolation, fire retardant, conditional chemical resistance	0.05

ISOLAY	Tile Size mm
Length	500
Width	500
Height	45

Static loading Pressure SLP kPa	Vertical Natural Frequencies <i>fdv</i>					
	Passive ISOLAY NR	<i>fdv</i> Hz	Active ISOLAY BR	<i>fdv</i> Hz	Active ISOLAY CR	<i>fdv</i> Hz
5	NR-45	17	BR-45	20	CR-45	18
10	NR-45	12	BR-45	14	CR-45	13
15	NR-45	10	BR-45	11	CR-45	11
20	NR-45	8	BR-45	10	CR-45	9
25	NR-60	11	BR-60	11	CR-60	11
30	NR-60	10	BR-60	10	CR-60	10
40	NR-60	8.6	BR-60	8.6	CR-60	8.6
48	NR-60	8	BR-60	8	CR-60	8



In order to increase Static Loading pressure **SLP** on **ISOLAY** up to 50% of area can be replaced by **ISOFOAM ISF**.

Tiles can be cut by circular, band or jig saw. Unsupported edges must be supported with **ISOFOAM ISF** strips. Tape all Isolay to side wall Void Filler/Foam joints.

# FAVIM FVM-50 Full Area Shock and Vibration Isolation Material

Full area vibration damping and sound deadening materials for foundations, plinths and floating floors can be applied to either a concrete base or consolidated hardcore

**Applications include:** Machinery, HVAC, lifts and elevators, workshops, pumps, compressors and generators, industrial storage and working areas, expansion joints, helicopter pads. Ideally suited for **low pressure** applications.

**Construction:** Recycled rubber particles with a polyurethane PUR binder.

**Properties:** Mildew and moisture proof  
 Permanently elastic / Low long term creep  
 Temperature range °C: -30 to +110  
 Density: 450 kg/m<sup>3</sup>



**Building materials class:** B2

**Standard Sheets:** 1.25m x 1.0m, 1.0m x 1.0m, 1.0m x 0.5m. Other sizes, pads and strips available on request.

Favim can be applied either direct to a consolidated hardcore base or a reinforced concrete pit base depending upon the site conditions

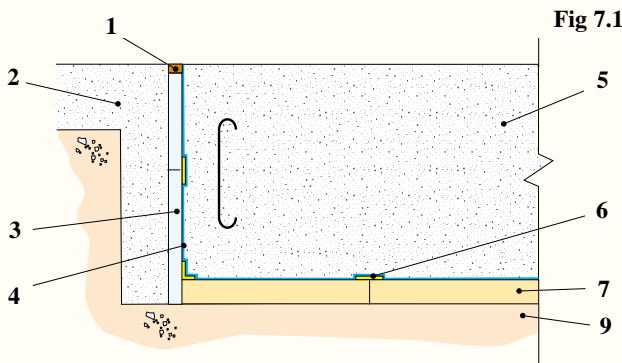

**Fig 7.1**

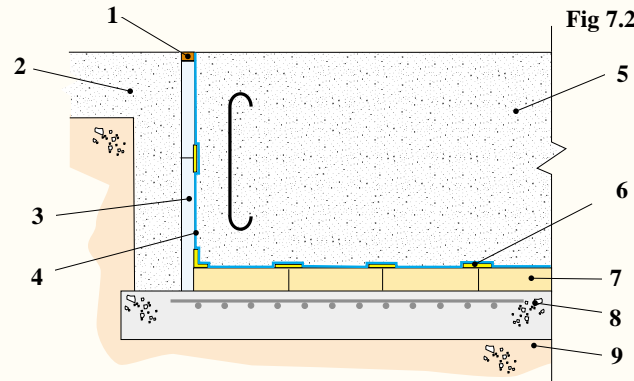

**Fig 7.2**

**Description of Diagram**

- 1) Polymeric sealant or sealing strip (Not supplied by Farrat)
- 2) Reinforced impermeable concrete to sides and base of pit. (Fig 7.2) Thickness and concrete specification to be determined by ground and loading conditions.\*
- 3) Farrat **LVI** or **ISF** side wall vibration isolation material, spot bonded to pit walls using WB Adhesive.
- 4) Damp proof membrane DPM. Minimum 1000gsm.
- 5) Steel cage reinforced concrete foundation block designed to support imposed dynamic and static loads and suitable for elastic support.\*
- 6) **JLT** Joint line tape to all joints.
- 7) **Favim 50** full area vibration isolation material to the pit base.
- 8) Reinforced concrete pit base.\* (Fig 7.2)
- 9) Consolidated hardcore base.

Favim 50 Full area vibration isolation material							
Performance table to be used as a guide only.							
Product	Favim	FVM	50-12	FVM	50-25	FVM	50-50
Static Loading Pressure SLP kPa	Dynamic Comp. Modulus Edc MPa	Static Deflection δ mm	Dynamic Vert. Nat. Frequency fvd Hz	Static Deflection δ mm	Dynamic Vert. Nat. Frequency fvd Hz	Static Deflection δ mm	Dynamic Vert. Nat. Frequency fvd Hz
10	1.33	0.8	52	1.6	37	3.2	26
12	1.45	0.8	49	1.7	35	3.4	25
14	1.48	0.9	47	1.8	33	3.5	24
15	1.53	0.9	45	1.8	32	3.6	23
18	1.61	1.0	43	2.0	30	4.0	21
22	1.63	1.1	40	2.2	29	4.4	20
25	1.65	1.2	37	2.4	26	4.7	18
31	1.63	1.4	34	2.8	24	5.7	17
41	1.63	1.8	30	3.7	21	7.3	15
50	1.63	2.2	26	4.4	18	8.8	13

Dynamic vertical natural frequency	<b>fvd</b>	Hz	= (1/(N) <sup>0.5</sup> )* fvd (for one layer)
Static deflection	<b>δ</b>	mm	= N x deflection for one layer
Specific spring constant	<b>Kss</b>	N/mm/mm <sup>2</sup>	= Kss (for one layer)/N
Spring constant	<b>K</b>	N/mm	= Area mm <sup>2</sup> *Kss
Vertical natural frequency	<b>fvd</b>	Hz	= 15.76*(1/d) <sup>0.5</sup>
Number of layers	<b>N</b>		

\* Reinforced concrete foundation blocks and associated structures to be designed by qualified consulting engineers and constructed by contractors of proven ability and experience.

Product	Thickness mm
<b>FVM 50-12</b>	<b>12.5</b>
<b>FVM 50-25</b>	<b>25</b>
<b>FVM 50-50</b>	<b>50</b>

Other thicknesses available on request.

# FAVIM FVM-100 Full Area Shock and Vibration Isolation Material



Full area vibration damping and sound deadening materials for foundations, plinths and floating floors can be applied to either a concrete base or consolidated hardcore

**Applications include:** Machinery, HVAC, lifts and elevators, workshops, pumps, compressors and generators, industrial storage and working areas, expansion joints, helicopter pads.  
Ideally suited for **medium pressure** applications.

**Construction:** Recycled rubber particles with a polyurethane PUR binder.

**Properties:** Mildew and moisture proof  
Permanently elastic / Low long term creep  
Temperature range °C: -30 to +110  
Density: 550 kg/m<sup>3</sup>

**Building materials class:** B2

**Standard Sheet:** 1.25m x 1.0m, 1.0m x 1.0m, 1.0m x 0.5m.  
Other sizes, pads and strips available on request.

Favim can be applied either direct to a consolidated hardcore base or a reinforced concrete pit base depending upon the site conditions

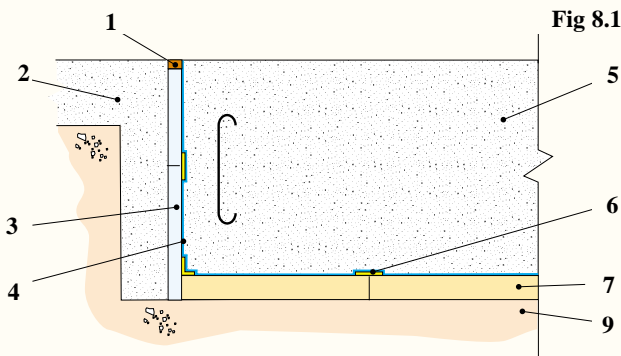

Fig 8.1

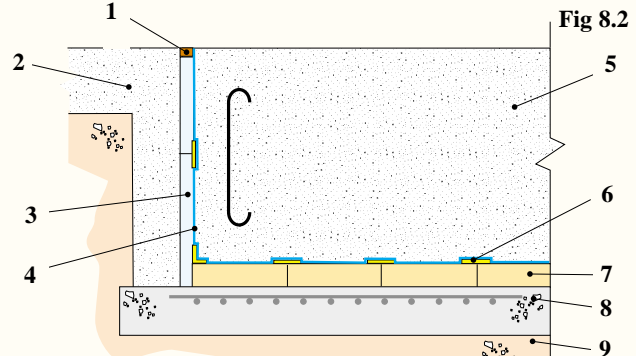

Fig 8.2

### Description of Diagram

- 1) Polymeric sealant or sealing strip (Not supplied by Farrat).
- 2) Reinforced impermeable concrete to sides and base of pit. (Fig 8.2) Thickness and concrete specification to be determined by ground and loading conditions.\*
- 3) Farrat LVI or ISF side wall vibration isolation material, spot bonded to pit walls using WB Adhesive.
- 4) Damp proof membrane DPM. Minimum 1000gsm.
- 5) Steel cage reinforced concrete foundation block designed to support imposed dynamic and static loads and suitable for elastic support.\*
- 6) JLT Joint line tape to all joints.
- 7) Favim 100 full area vibration isolation material to the pit base.
- 8) Reinforced concrete pit base.\* (Fig 8.2)
- 9) Consolidated hardcore base.

Favim 100 Full area vibration isolation material							
Performance table to be used as a guide only.							
Product	Favim	FVM	100-12	FVM	100-25	FVM	100-50
Static Loading Pressure SLP kPa	Dynamic Comp. Modulus Edc MPa	Static Deflection δ mm	Dynamic Vert. Nat. Frequency fvd Hz	Static Deflection δ mm	Dynamic Vert. Nat. Frequency fvd Hz	Static Deflection δ mm	Dynamic Vert. Nat. Frequency fvd Hz
25	2.57	0.2	43	0.5	30	0.9	22
30	2.63	0.3	41	0.7	29	1.3	20
40	2.63	0.5	37	1.1	26	2.2	19
50	2.64	0.8	31	1.5	22	3.0	16
60	2.65	1.0	29	2.0	20	4.1	14
70	2.65	1.3	27	2.5	19	5.1	13
75	2.65	1.4	26	2.8	18	5.6	13
80	2.70	1.6	25	3.1	18	6.2	12
90	2.70	1.9	24	3.7	17	7.5	12
100	2.71	2.2	23	4.4	16	8.7	11
Dynamic vertical natural frequency			<i>fvd</i>	Hz	= (1/(N) <sup>0.5</sup> )* <i>fvd</i> (for one layer)		
Static deflection			<i>δ</i>	mm	= N x deflection for one layer		
Specific spring constant			<b>Kss</b>	N/mm/mm <sup>2</sup>	= Kss (for one layer)/N		
Spring constant			<b>K</b>	N/mm	= Area mm <sup>2</sup> *Kss		
Vertical natural frequency			<i>fvd</i>	Hz	= 15.76*(1/d) <sup>0.5</sup>		
Number of layers			<b>N</b>				

\* Reinforced concrete foundation blocks and associated structures to be designed by qualified consulting engineers and constructed by contractors of proven ability and experience.

Product	Thickness mm
FVM 100-12	12.5
FVM 100-25	25
FVM 100-50	50

Other thicknesses available on request.

# FAVIM FVM-200 Full Area Shock and Vibration Isolation Material

Full area vibration damping and sound deadening materials for foundations, plinths and floating floors can be applied to either a concrete base or consolidated hardcore



**Applications include:** Machinery, HVAC, lifts and elevators, workshops, pumps, compressors and generators, industrial storage and working areas, expansion joints, helicopter pads. Ideally suited for **high pressure** applications.

**Construction:** Recycled rubber particles with a polyurethane PUR binder.  
**Properties:** Mildew and moisture proof  
 Permanently elastic / Low long term creep  
 Temperature range °C: -30 to +110  
 Density: 750 kg/m<sup>3</sup>

**Building materials class:** B2

**Standard Sheets:** 1.25m x 1.0m, 1.0m x 1.0m, 1.0m x 0.5m. Other sizes, pads and strips available on request.

Favim can be applied either direct to a consolidated hardcore base or a reinforced concrete pit base depending upon the site conditions

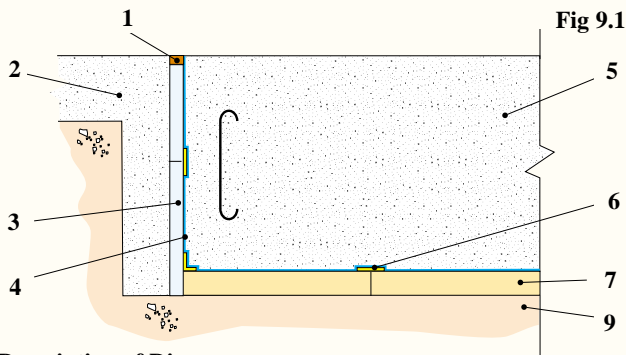

**Fig 9.1**

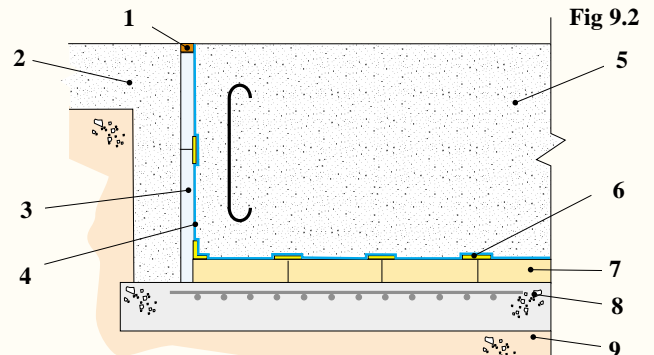

**Fig 9.2**

**Description of Diagram**

- 1) Polymeric sealant or sealing strip (Not supplied by Farrat).
- 2) Reinforced impermeable concrete to sides and base of pit. (Fig 9.2) Thickness and concrete specification to be determined by ground and loading conditions.\*
- 3) Farrat **LVI** or **ISF** side wall vibration isolation material, spot bonded to pit walls using WB Adhesive.
- 4) Damp proof membrane DPM. Minimum 1000gsm.
- 5) Steel cage reinforced concrete foundation block designed to support imposed dynamic and static loads and suitable for elastic support.\*
- 6) **JLT** Joint line tape to all joints.
- 7) **Favim 200** full area vibration isolation material to the pit base.
- 8) Reinforced concrete pit base.\* (Fig 9.2)
- 9) Consolidated hardcore base.

<b>Favim 200</b>							
<b>Full area vibration isolation material</b>							
				Performance table to be used as a guide only.			
Product	Favim	FVM	200-12	FVM	200-25	FVM	200-50
Static Loading Pressure <b>SLP</b> kPa	Dynamic Comp. Modulus <b>E<sub>dc</sub></b> MPa	Static Deflection <b>δ</b> mm	Dynamic Vert. Nat. Frequency <b>f<sub>vd</sub></b> Hz	Static Deflection <b>δ</b> mm	Dynamic Vert. Nat. Frequency <b>f<sub>vd</sub></b> Hz	Static Deflection <b>δ</b> mm	Dynamic Vert. Nat. Frequency <b>f<sub>vd</sub></b> Hz
<b>50</b>	4.08	0.4	41	0.8	29	1.6	23
<b>66</b>	4.37	0.5	37	1.1	26	2.1	21
<b>83</b>	4.44	0.7	35	1.4	25	2.7	19
<b>100</b>	4.51	0.8	30	1.6	21	3.3	15
<b>116</b>	4.96	0.9	29	1.9	20	3.7	14
<b>132</b>	5.07	1.0	28	2.1	20	4.2	14
<b>150</b>	5.17	1.2	26	2.3	19	4.7	13
<b>166</b>	5.51	1.3	26	2.6	18	5.3	13
<b>183</b>	5.59	1.5	25	2.9	17	5.9	12
<b>200</b>	5.67	1.6	24	3.2	17	6.5	12
Dynamic vertical natural frequency			<b>f<sub>vd</sub></b>	Hz	= (1/(N) <sup>0.5</sup> )* f <sub>vd</sub> (for one layer)		
Static deflection			<b>δ</b>	mm	= N x deflection for one layer		
Specific spring constant			<b>K<sub>ss</sub></b>	N/mm/mm <sup>2</sup>	= K <sub>ss</sub> (for one layer)/N		
Spring constant			<b>K</b>	N/mm	= Area mm <sup>2</sup> *K <sub>ss</sub>		
Vertical natural frequency			<b>f<sub>vd</sub></b>	Hz	= 15.76*(1/d) <sup>0.5</sup>		
Number of layers			<b>N</b>				

\* Reinforced concrete foundation blocks and associated structures to be designed by qualified consulting engineers and constructed by contractors of proven ability and experience.

Product	Thickness mm
<b>FVM 200-12</b>	<b>12.5</b>
<b>FVM 200-25</b>	<b>25</b>
<b>FVM 200-50</b>	<b>50</b>

Other thicknesses available on request.

## LVI Lateral Vibration Isolation material

### Applications

Vibration damping and isolation material specifically designed for side wall vibration isolation of foundations. Particularly suited to **sensitive machinery such as printing machines**. Provides the best degree of isolation when used in conjunction with an **ISOMAT** or **FAVIM** isolated foundation base.

**Construction:** Recycled rubber particles with a polyurethane PUR binder.

**Building materials class:** B2

**Standard Sheet Sizes:** 1m x 0.5m x 50mm. Pads, Strips and other sheet sizes available.

Farrat LVI 440 material		
Static Compression Modulus	N/mm <sup>2</sup>	0.15-0.33
Dynamic Compression Modulus	N/mm <sup>2</sup>	0.29-1*
Specific Static Spring Constant	N/mm/mm <sup>2</sup>	0.006
Creep after 70 Hrs at max pressure	%	4
Max Static Pressure	kPa	100
Deflection at Maximum Pressure	mm	14.6
Natural Frequency Range	Hz	10-25
Operating Temperature Range	°C	-30 to 120
Standard Thickness	mm	50/25
Density	kg/m <sup>3</sup>	440
* Dependant upon disturbing frequency		



## ISF Isofoam Sidewall Vibration Isolation Material

### Applications

Vibration damping and isolation material specifically designed for side wall vibration isolation of foundations. Can also be used as a base isolation material where required.

Provides the best degree of side wall isolation when used in conjunction with an **ISOMAT**, **FAVIM** or **ISOLAY** foundation base.

**Construction:** EPDM closed cell rubber foam.

**Building materials class:** B2

**Standard Sheet Sizes:** 2m x 1m and 1m x 1m. Pads, Strips and other sheet sizes available.

Farrat ISF material		
Static Compression Modulus	N/mm <sup>2</sup>	0.17
Dynamic Compression Modulus	N/mm <sup>2</sup>	0.17-0.8*
Specific Static Spring Constant	N/mm/mm <sup>2</sup>	0.007
Creep after 70 Hrs at max pressure	%	10
Max Static Pressure	kPa	100
Deflection at Maximum Pressure	mm	21.8
Natural Frequency Range	Hz	8-20
Operating Temperature Range	°C	-30 to 120
Standard Thickness	mm	50/45/40/25
Density	kg/m <sup>3</sup>	150
* Dependant upon disturbing frequency		

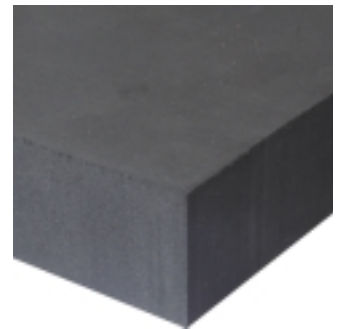

## FVF Void Filler Sidewall and Base Void Filler Material

### Applications

FVF Void filler can be used as either a side wall void filler or a base void filler between **ISOMAT** isolators. Particularly useful when pouring inertia blocks to maintain a constant void between inertia block and surrounding structure.

**Construction:** Expanded styrene foam.

**Building materials class:** B2

**Standard Sheet Sizes:**

2.4m x 1.2m and 1.2m x 1.2m.

Pads, Strips and other sheet sizes available.

Farrat FVF material		
Static Compression Modulus	N/mm <sup>2</sup>	0.4
Dynamic Compression Modulus	N/mm <sup>2</sup>	N/A
Specific Static Spring Constant	N/mm/mm <sup>2</sup>	0.011
Creep after 70 Hrs at max pressure	%	30
Max Static Pressure	kPa	50
Deflection at Maximum Pressure	mm	15
Natural Frequency Range	Hz	15-30
Operating Temperature Range	°C	-30 to 120
Standard Thickness	mm	50 / 25
Density <b>FVF-10</b> (for bases)	kg/m <sup>3</sup>	10
Density <b>FVF-15</b> (for sidewall)	kg/m <sup>3</sup>	15

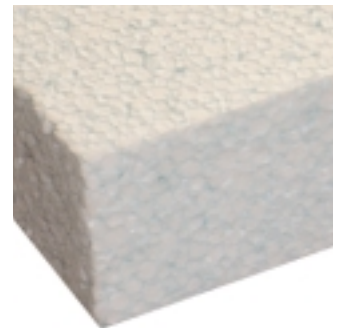

LVI or ISF can be used on its own or in conjunction with a base isolation material e.g. Favim, Isolay or Isomat.

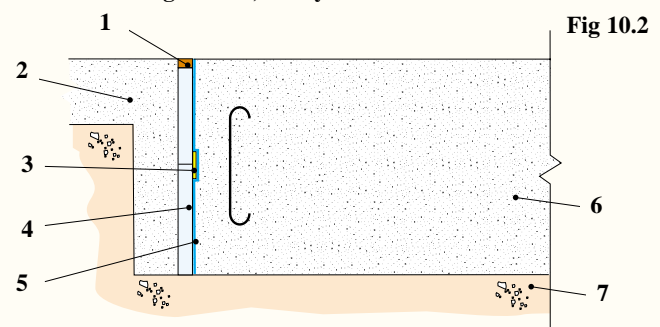
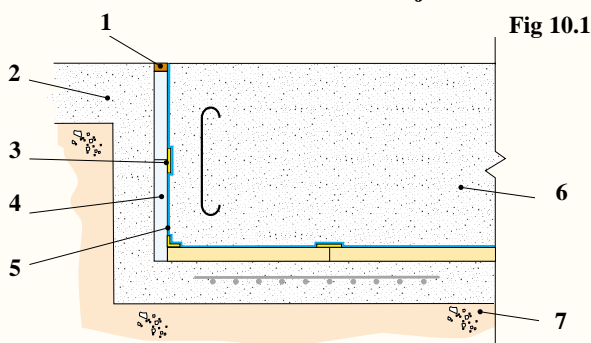

### Description of Diagram

- 1) Polymeric sealant or sealing strip (Not supplied by Farrat)
- 2) Reinforced impermeable concrete to sides and base of pit. Thickness and concrete specification to be determined by ground and loading conditions.
- 3) **JLT** Joint line tape to all joints.
- 4) Farrat **LVI, ISF or FVF** side wall vibration isolation material, spot bonded to pit walls using **WB Adhesive**.
- 5) Damp proof membrane **DPM**. Minimum 1000gsm.
- 6) Steel cage reinforced concrete foundation block designed to support imposed dynamic and static loads and suitable for elastic support.
- 7) Consolidated hardcore base

Spring isolation units type FSL comprise a group of heavy duty helical springs contained within robust steel platforms.

**Applications**

FSL springs can be used either under a foundation or mounted directly under machinery or building structures.

**Construction**

Fabricated steel platforms used with helical springs to BS 1726-1:2002. As standard the springs are painted black and the platforms are painted to the customer's colour choice.

**Properties**

Low frequency vibration isolation for sensitive machinery.

**Description of Diagram Fig 11.1**

- 1) Re-enforced impermeable concrete pit.\*
- 2) Farrat FV damper.
- 3) Re-enforced concrete foundation block.\*
- 4) Farrat FSL springs.
- 5) Consolidated hardcore to firm ground.\*

\* Reinforced concrete foundation blocks and associated structures to be designed by qualified consulting engineers and constructed by contractors of proven ability and experience.

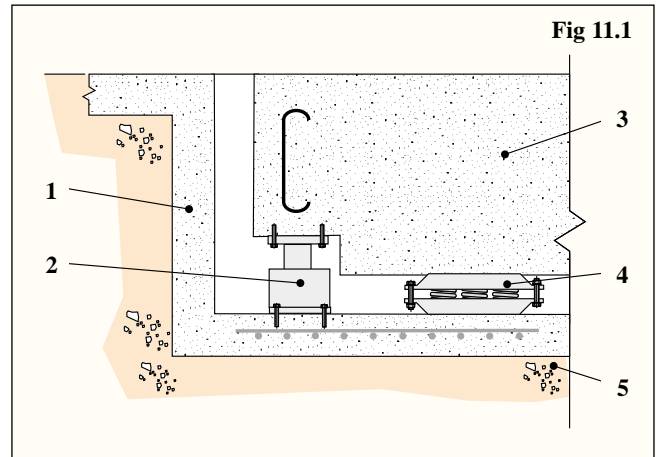

FSL Steel Springs can be used either on their own or in tandem with FV dampers. Where the system is likely to go through resonance and excessive movement is a concern it is recommended that FV dampers are used in conjunction with FSL springs. FSL steel springs can be employed in a variety of combinations and support arrangements, Farrat will design isolation systems to meet a customer's specific technical requirements. To assist our customers in the smooth running of every project Farrat provide construction drawings and installation instructions with all FSL springs supplied.

Product	Length	Width	Spring rate	Load Per Unit at		Natural Frequency at		Isolator Height at		
				Max. load	Min. load	Max. load	Min. load	Max. load	Min. load	Free
	mm	mm	kN/mm	kN	kN	Hz	Hz	mm	mm	mm
FSL 1-4	500	305	3.4	85	28	3.2	5.5	140	157	165
FSL 1-6	550	305	5.1	128	42	3.2	5.5	140	157	165
FSL 1-8	725	305	6.8	170	56	3.2	5.5	140	157	165

# FARRAT FV Viscous Dampers

Farrat FV dampers have the effect of limiting the motion of spring supported systems. Where a system is likely to travel through resonant frequencies or is subject to shock loads the undamped movement can be relatively high. The incorporation of a viscous damping in such a system will limit movement by converting the kinetic energy of the movement into heat within the viscous fluid of the damper.

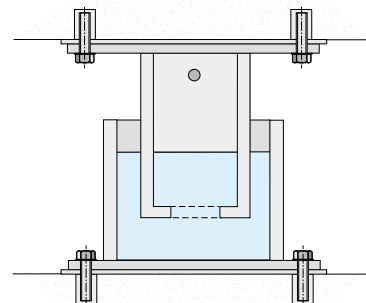

Fig 11.2

Product	Width	Length	Working Height	Damping Ratio
	mm	mm	mm	C/Cc
FV 1	250	250	300	0.2-0.5
FV 2	330	330	400	0.2-0.5
FV 3	406	406	450	0.2-0.5

The standard type FV DAMPER UNITS are available in three sizes. Damper size required will depend upon the mass being supported and the system natural frequency. Resilient pads to isolate higher frequencies are provided for the top and bottom plates together with suitably sized "cast in" sockets and fixing screws. Damping fluid is supplied in separate containers. Farrat will work with you to advise and supply the correct damper for your application.

Low frequency shock and vibration isolators with damping.

Incorporated into the spring unit is an integral damper to provide a limitation to the forces transmitted at resonant frequencies.

**Applications**

FSLV Spring dampers can be used either under a foundation or mounted directly under the machine/structure.

**Construction**

Fabricated steel platforms with integral dampers enclosing helical springs to BS 1726-1:2002.

As standard the springs are painted black and the platforms are painted to the customer’s colour specification.

**Properties**

Ideal for machines that are likely to travel through resonant frequencies.

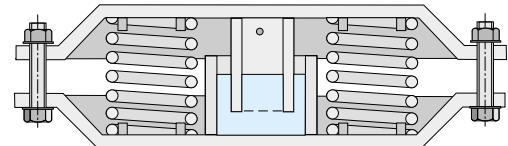
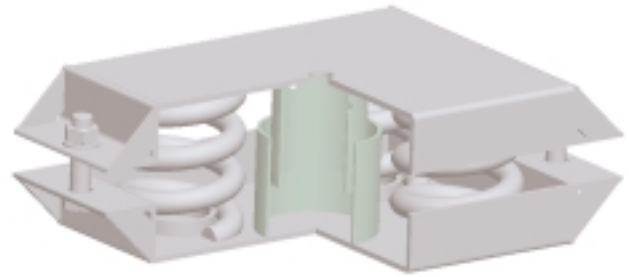

**Fig 12.1**

**FSLV units can be used on their own or combined with FSL units.** **Fig 12.2**

**Description of Diagram**

- 1) Re-enforced impermeable concrete pit. \*
- 2) Farrat FSLV spring dampers.
- 3) Re-enforced concrete foundation block.\*
- 4) Consolidated hardcore to firm ground. \*

\* Reinforced concrete foundation blocks and associated structures to be designed by qualified consulting engineers and constructed by contractors of proven ability and experience.

Product	Length mm	Width mm	Spring rate kN/mm	Load Per Unit at		Natural Frequency at		Isolator Height at			Damping Ratio C/Cc
				Max load kN	Min load kN	Max load Hz.	Min. load Hz.	Max kN	Min kN	Free kN	
<b>FSLV 1-4</b>	500	305	3.4	85	28	3.2	5.5	140	157	165	0.15
<b>FSLV 1-6</b>	720	305	5.1	127	42	3.2	5.5	140	157	165	0.15
<b>FSLV 1-8</b>	850	305	6.8	170	56	3.2	5.5	140	157	165	0.15

FSLV Steel springs can be employed in a variety of combinations and support arrangements, Farrat will design isolation systems to meet a customers specific technical requirements. To assist our customers in the smooth running of every project Farrat provide construction drawings and installation instructions with all FSLV springs supplied.



ISOLAY isolated foundation for CNC Machining Centre



CNC machining centre on ISOLAY isolated foundation



ISOMAT isolated foundation for large Cerutti printing press



Cerutti Printing Press on ISOMAT isolated foundation

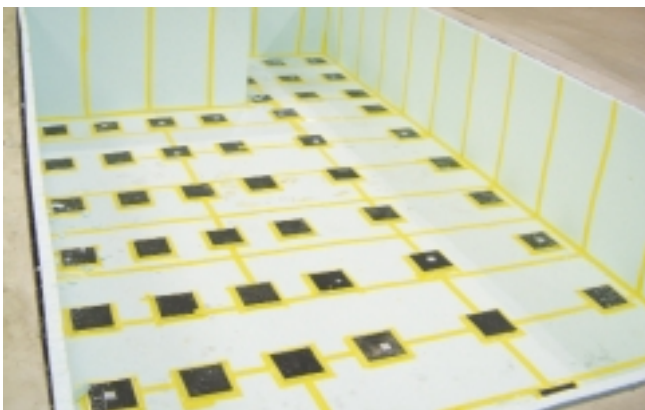

ISOMAT isolated foundation for Rhodes 2500 kN Power Press



Rhodes 2500kN Power Press on ISOMAT isolated foundation

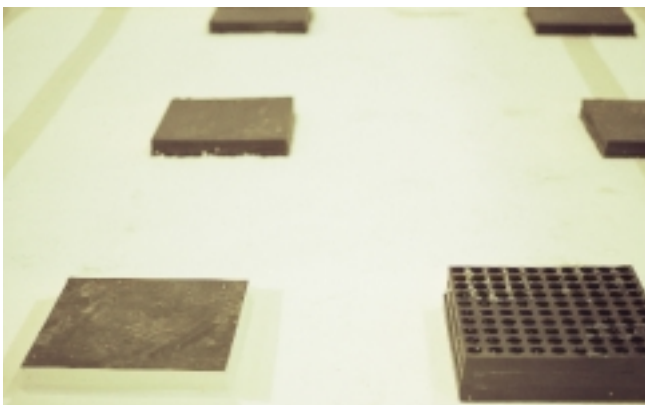

ISOMAT/FVF isolated foundation for metal recycling and crushing machine



Metal recycling and crushing machine on ISOMAT/FVF isolated foundation

Low Frequency Shock & Vibration for active and passive applications.

**Fig. 14.1**

In the case of spring and air mounts it is advisable to have an access gap around the foundation for maintenance reasons.

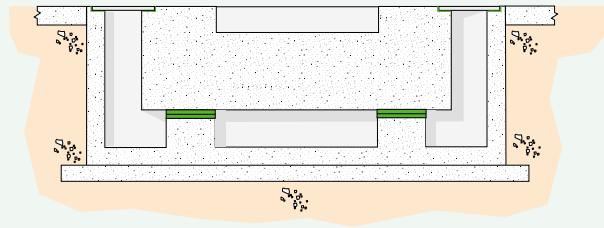
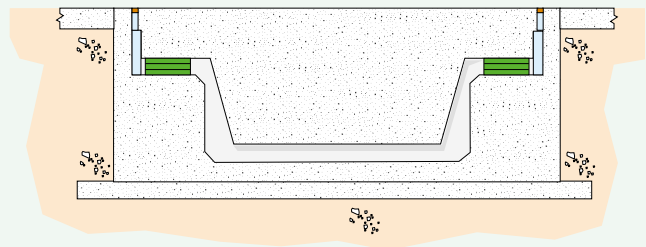

**Fig 14.1**

**Fig. 14.2 a/b**

Where a machine has a high center of gravity it is usually desirable to keep the centre of gravity as low as possible to avoid instability of both machine and foundation.

For this reason a stepped foundation block can be employed. By reducing the vertical distance between the anti vibration mount and the combined machine/foundation centre of gravity the stability of the entire system is dramatically increased.



**Fig 14.2a**

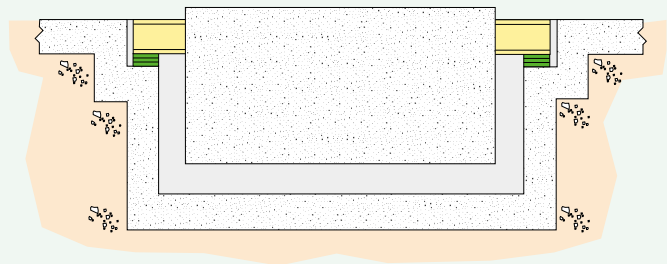

**Fig 14.2b**

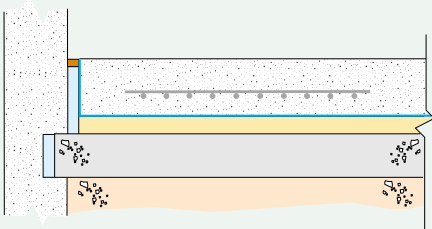
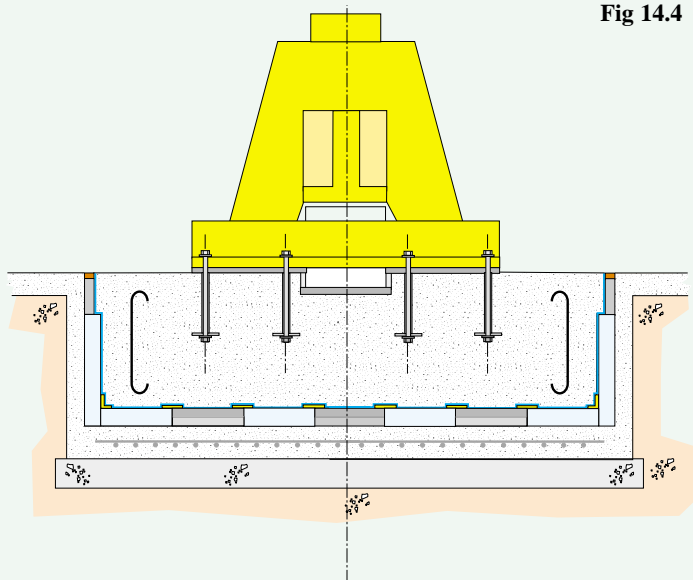

**Fig. 14.3** Floating floor, Isolay or Favim

**Fig. 14.5**

Where forging hammers and other such shock creating machinery is used it is advisable to put vibration isolation systems both directly under the machine and beneath the foundation block.

This has the effect of minimising the shock wave that is transmitted through the surrounding floor, thus reducing noise and structure borne vibration.



**Fig 14.4**

Structural borne noise and vibration isolation solutions for the building design and construction industry.

Farrat's range of anti-vibration materials can be used in all areas of construction to reduce noise & vibration across a wide frequency range. Produced from high quality materials, they are highly ozone resistant, have very low levels of creep and will last the lifetime of the structure. Contact Farrat specific literature and data.

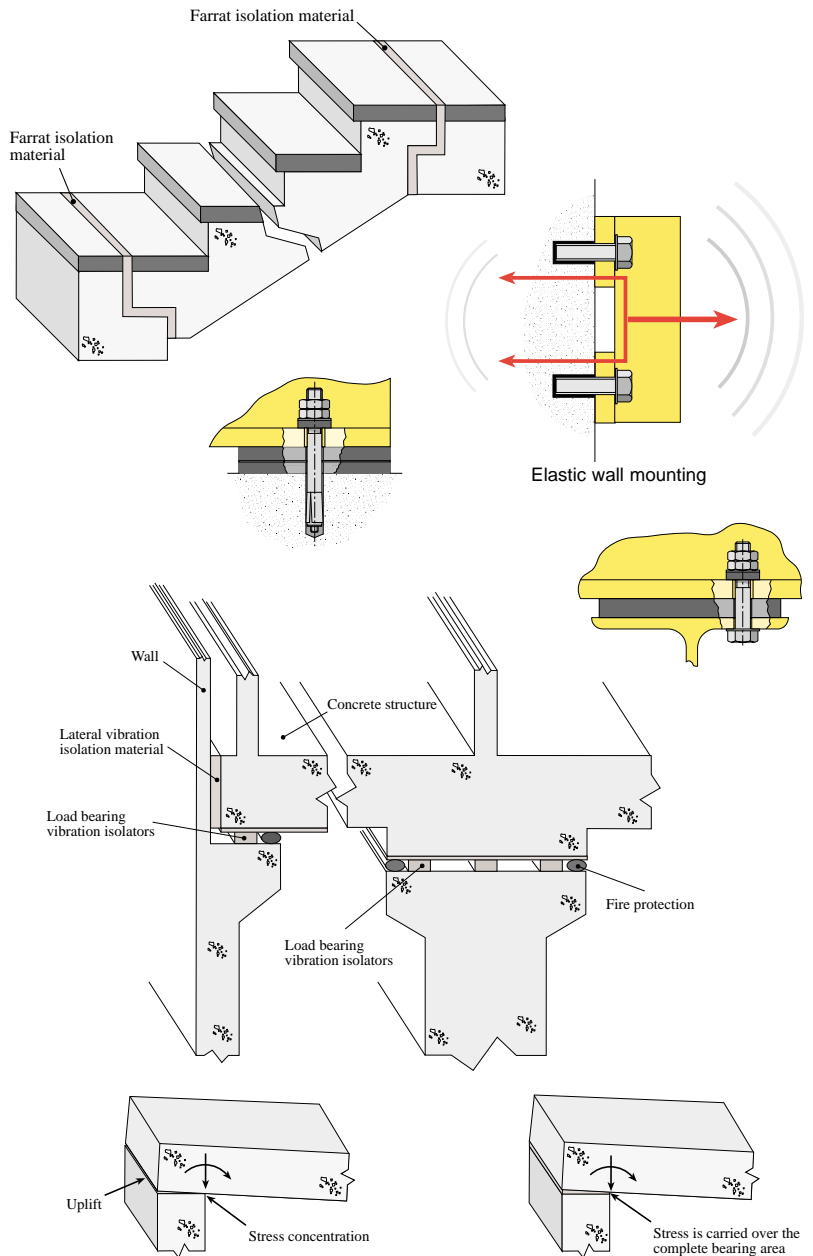

**Specific examples:**

- Floating floors
- Lifts & Escalators
- Mezzanine floors
- Noise propagation from external cladding
- Offshore accommodation / office blocks
- Plant-room equipment / M&A / HVAC
- Resilient seatings
- Room within a room systems
- Steelwork isolation
- Structural bearings / building decoupling
- Structural damage from: shrinkage, rotation, differential settlement and localised stresses
- Suspended conveyors
- Thermal partitions
- Wall & ceiling acoustic suspension elements

**Structures in which products are used:**

- Anechoic chambers
- Audiometry rooms
- Bowling alleys
- Care Homes
- Cinemas & Theatres
- Clubs, pubs & bars
- Computer and test rooms
- Concert halls
- Gymnasiums
- Hospitals
- Instrument rooms
- Nuclear power stations
- Railways
- Performing arts centres
- Quality control rooms
- Schools
- Sports halls
- TV, radio & studios

Farrat AV Materials for Structural Applications		
Product	Loading Pressure N/mm <sup>2</sup>	Available thicknesses (mm)
<b>Hamamat HM</b>	4-6	6, 10,15 & 25
<b>Neoprene CR</b>	0.5-6	6, 10, 15 & 25
<b>Vidam VM</b>	0.1-0.5	6, 10, 13, 20 & 25
<b>Nitrile NBR</b>	0.5-6	6, 8, 15 & 25

**Thermal Break Connection Plates FTB**

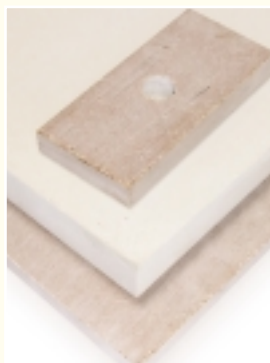

Very high loading, thermal insulation material to prevent thermal/cold bridging between internal and external steelwork.

Product	Max loading pressure N/mm <sup>2</sup>
<b>FTB 260</b>	<b>260</b>
<b>FTB 330</b>	<b>330</b>

Virtually no creep.  
Supplied in various thicknesses, sheets or cut to shape.  
Thermal conductivity: 0.27W/m.K

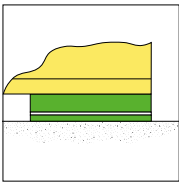
**Squaregrip (SG)**

High strength vibration damping material for machinery and equipment needing a stiff vibration damped support with minimum machine movement.

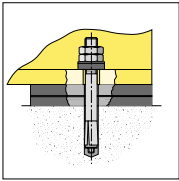
**NBR**

An elastic vibration isolation material with good shock and vibration isolation properties.

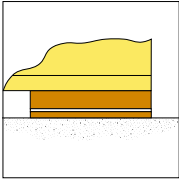
**Vidam (VM)**

General Purpose, rubber/cork based machine mounting material.

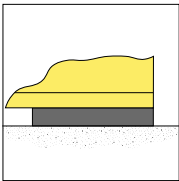
**Isomat (IM)**

High performance shock and vibration isolation material. Unique design provides increased elasticity and improved isolation efficiency.

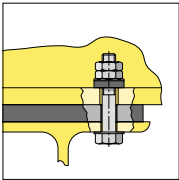
**Hamamat (HM)**

High impact, high strength and high stiffness shock and vibration absorbing material.

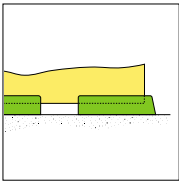
**Corner / Side Foot (CF, SF)**

General purpose machine mounting pads

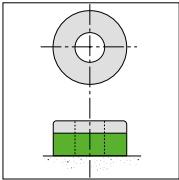
**Anti Vibration Washers (AW, AWS)**

To reduce vibration transmitted to, or from, holding down bolts

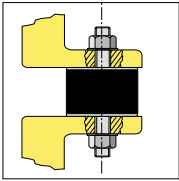
**Rubber to Metal Bobbins (RM)**

Versatile rubber-to-metal bonded vibration and shock isolators, available in a broad range of fixing configurations

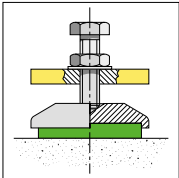
**Jackmounts (JCM, JRM, JSM, JMS)**

General purpose machine mounts. Different anti vibration versions depending on applications.

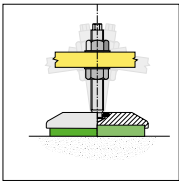
**Captive Jackmounts (JMP, JMSP)**

Machine mount with captive pendulum levelling screw. Cast iron and stainless steel versions.

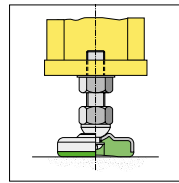
**MF Mounts (MF)**

Pressed Steel Mount fitted with Nitrile Rubber Pad for lighter applications. MF P: Zinc Plated Steel, MF S: Stainless Steel 304

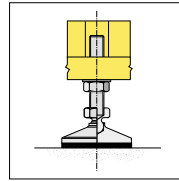
**Levelling Mount (LF)**

High precision stainless steel (304) levelling mounts with captive ball nosed levelling screws.

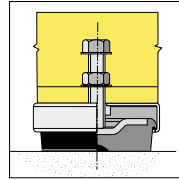
**Isomounts (ISO)**

Machine mount with vulcanized rubber base and built in levelling screws for height adjustment.

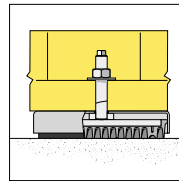
**Isobloc (ISB)**

High load capacity machine mount with vulcanized rubber base and built in levelling screws for height adjustment.

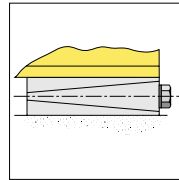
**Wedge Levelling Elements (WLE)**

Precision Wedge Levelling units for rigid machine support

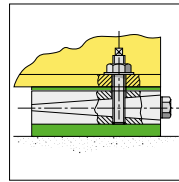
**Wedgemounts (WL, WLF, WLB, WLT)**

Height adjustable machine mounts based on screw driven three part machined cast iron wedges fitted with various types of vibration damping material.

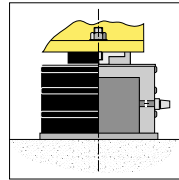
**Air Mount (SLM)**

Low profile, low frequency air spring suitable for both passive and dynamic applications where a support natural frequency of 3 - 5 Hz is required.

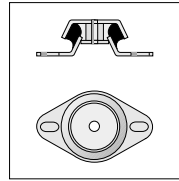
**Equipment Mount (CCF, CCFQ, LTS)**

All purpose vibration & shock isolators for the support of dynamic and rotating machinery

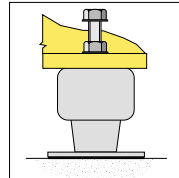
**Spring Mounts (SM)**

Low frequency anti-vibration mountings with damping control and adjustable levelling for efficient isolation of active and passive machinery.

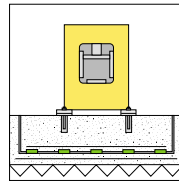
**Isolated Foundations (IF)**

Shock and vibration isolation for machine foundations and structures.



Farrat Isolevel Ltd.

Balmoral Road, Altrincham, Cheshire WA15 8HJ. England GB

Tel: +44 (0) 161 924 1600 Fax: +44 (0) 161 924 1616

email: sales@farrat.com www.farrat.com