

Isomat Acoustic Floating Floor Systems

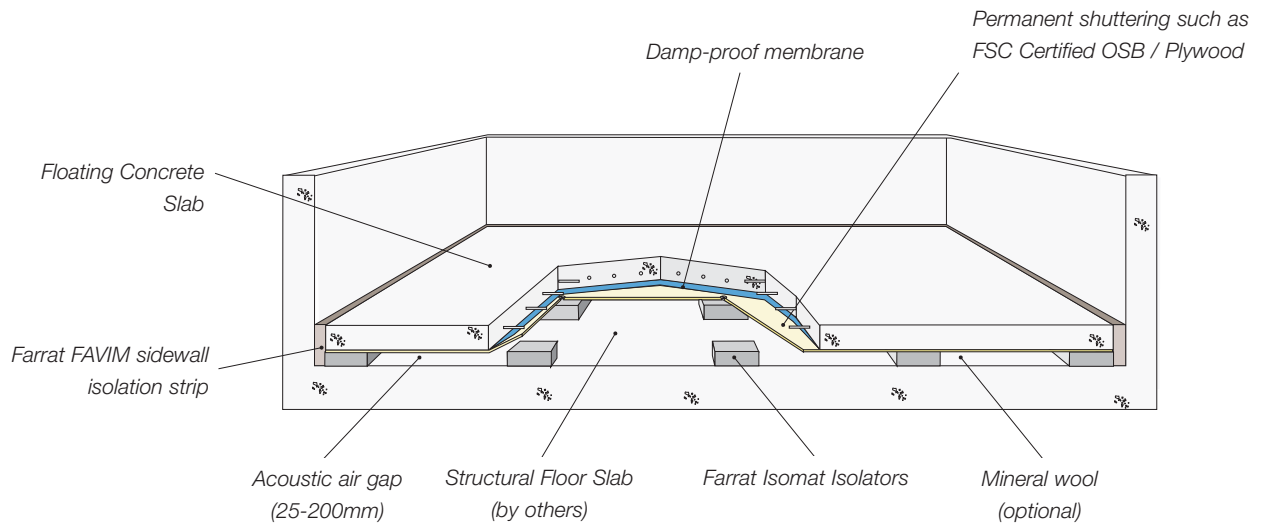

Isomat Acoustic Floating Floors Systems (IFFS) can be used in cinemas, theatres, gyms, bowling alleys etc.



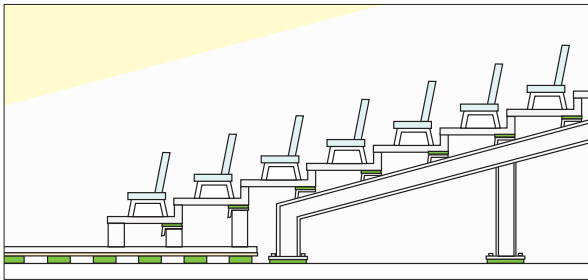

Fig 2.1 Cinemas, Theatres, Concert Halls etc.
An Isomat Floating Floor combined with Isomat pads (or other Farrat anti vibration pad materials) as isolation of tiered seating steelwork or precast concrete can create a fully isolated system.

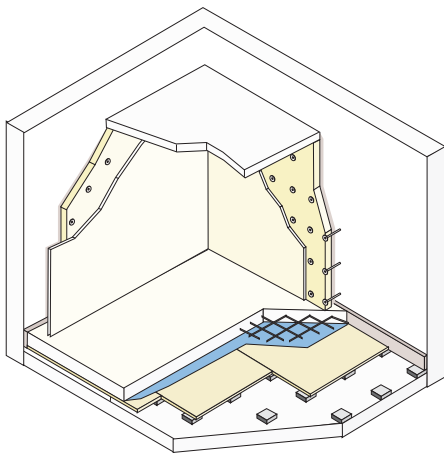

Fig 2.2 Recording Studios, Nightclubs, Plant Rooms etc. Internal walls and structures can be installed onto the floating slab to create a **box in box** structure with the acoustic air void created on all sides.

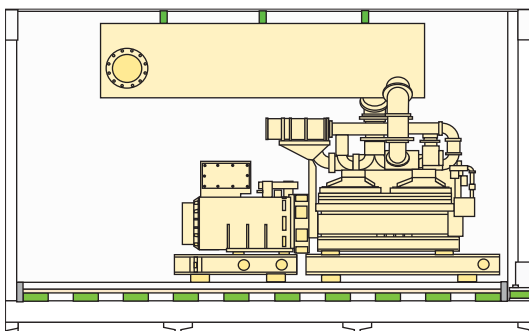

Fig 2.3 Plant rooms

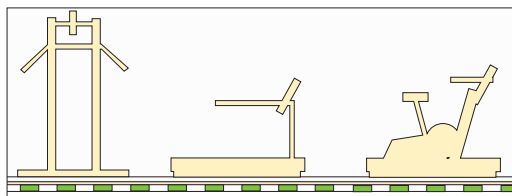

Fig 2.4 Gymnasiums, fitness suites

Why choose a Farrat Isomat Acoustic Floating Floor System (IFFS):

Farrat Isomat Acoustic Floating Floors

are used extensively in buildings as architectural isolation products to prevent acoustic and structure borne vibration disturbance from propagating through the structure especially where quiet spaces are located near sources of noise and vibration.

They have been developed by Farrat to provide high levels of acoustic and vibration isolation performance whilst being economical, easy and quick to install and incorporating mostly recycled or sustainable components.

Flexibility in design, layout, acoustic & load bearing performance:

- Natural frequencies down to 6Hz.
- Acoustic air gap between 25 & 200mm.
- Floating concrete slab thicknesses between 50 & 2000mm.
- Load bearing capacity up to 900kN/m².
- Isomat load bearing capacity up to 900kN/m².

Sustainability: The 'dry' system (excluding concrete) can comprise of up to 90% recycled or sustainable materials.

Flexibility in delivery: Systems can be supplied fully installed or as an isolator kit for customer installation.

Ease, speed and adaptability.

Economical.

Use of high quality, long lifetime materials.

Typical applications include:

- Cinemas, theatres, performing arts facilities and concert halls
- Bowling alleys
- Nightclub dance floors
- Broadcasting and recording studios
- Conference rooms
- Hotels
- Gymnasiums, fitness suites
- Manufacturing facilities (CMM rooms etc)
- Hospital operating theatres & sensitive equipment areas
- Mechanical equipment, plant and back up generator rooms
- Helicopter landing pads
- Instrument and nanotechnology facilities
- Anechoic chambers
- Residential dwellings and offices
- Buildings located near major road or rail networks
- Bowling Alleys

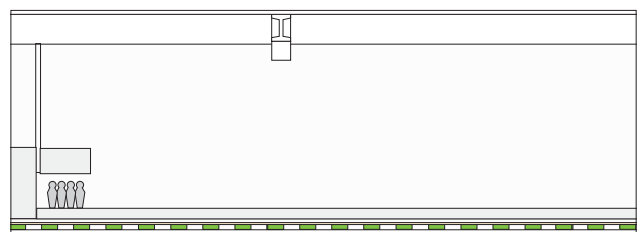
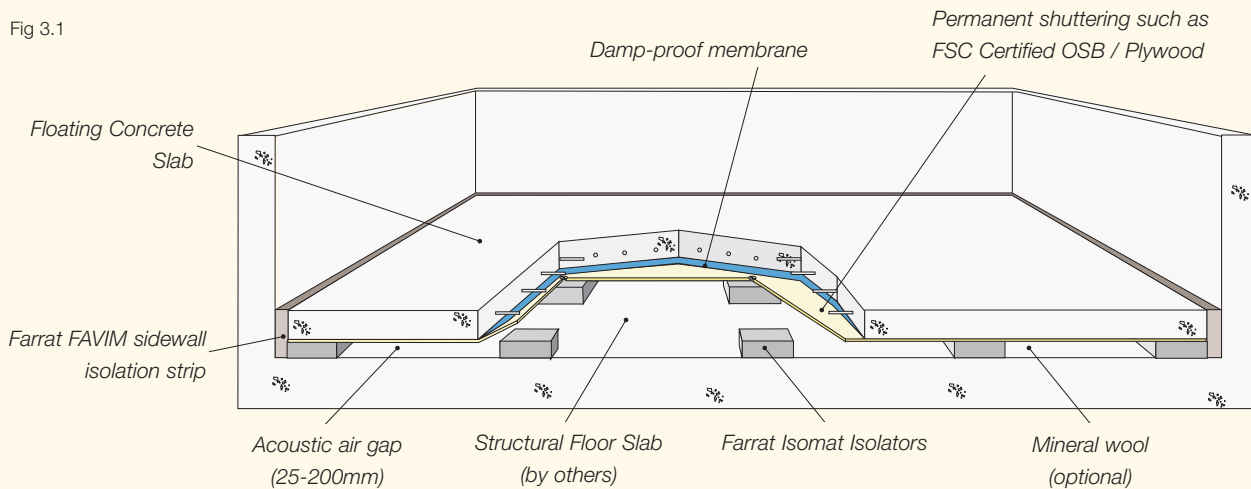

Fig 2.5 Bowling alley

System Principle

There are two fundamental elements to a floating floor;

Fig 3.1



1: For example the typical STC (Sound Transmission Class) of a 150mm thick structural concrete slab provided there is no flanking is in the region of 54dB whereas for a 150mm thick structural concrete slab + 50mm air gap + 15mm ply + 100mm floating slab the STC rises to approximately 79dB provided there is no flanking. This equates to an improvement (loss) of 25dB.

2: The vertical and horizontal isolators act to 'decouple' the floating floor from the rest of the building structure preventing the propagation of structure-borne vibration into or out of the isolated room. Natural frequencies can be tuned according to the project requirements but can be as low as 6Hz.

Based on the specification requirements for a specific building or application, usually established by an acoustic consultant, Farrat can advise on the most suitable type and grade of floating floor system and work with the project team to provide a full system specification.

Fig 3.2

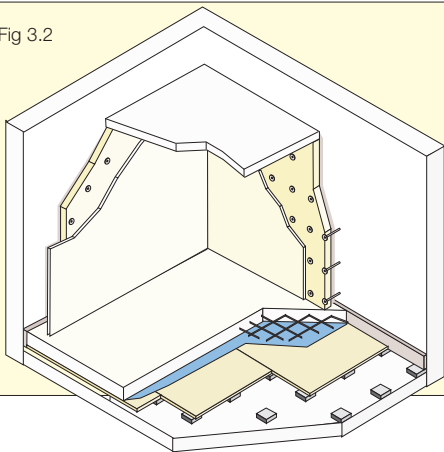

Box in Box

The complete solution, full Box in Box systems can be used for cinemas, TV and radio recording studios, conference facilities etc to provide the highest level of acoustic isolation properties with the minimum risk of flanking transmission paths.

Box in Box Systems consist of an Isomat floating floor where the internal walls of the room are installed directly onto the floating slab and supported by resilient wall ties resulting in a room which is completely decoupled from the surrounding building structure.

It is imperative that during construction, no solid 'bridges' exist between the floating floor, walls or ceiling as they will reduce the effectiveness of the system.

Isomat

With load bearing isolators, precise performance, durability and minimal creep are of paramount importance. In order to provide this we have used Isomat which is a specialist anti-vibration material developed and manufactured by Farrat.

Produced from high quality ISO6446 grade Neoprene (Chloroprene CR) rubber it has been tested according to BS6177 (Selection and use of elastomeric bearings for vibration isolation of buildings) and has been very successfully used for decades in all kinds of building structure and industrial applications such as cinema raked seating isolation, isolated foundations, structural bearings etc.



For any assistance or further information on Farrat IFFS and general acoustic and vibration isolation queries we invite you to contact us.
Tel: +44 (0) 161 924 1600 Email: sales@farrat.com Web: www.farrat.com

Typical Installation Sequence

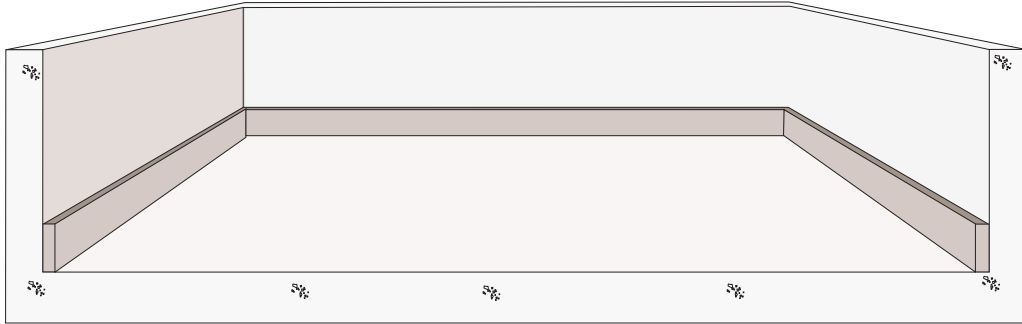

Fig 4.1 Ensure floor area is clean, clear of debris and level. Bond the FAVIM lateral isolation strips (supplied in 1 meter lengths) to the perimeter walls, edges and any protrusions into or through the floor. If the perimeter walls are not in place, erect lateral formwork.

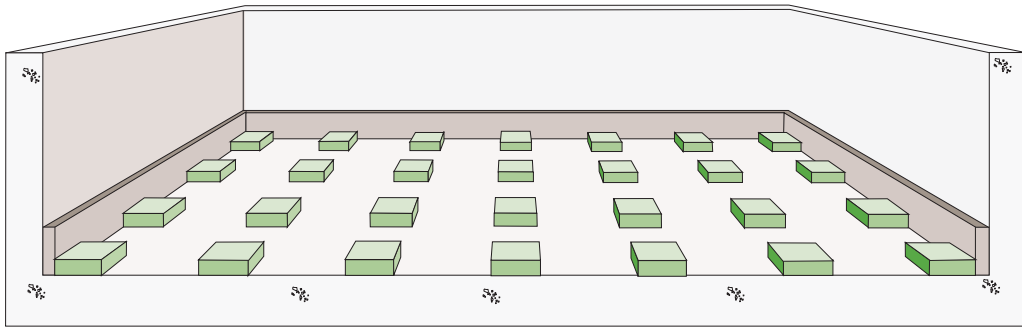

Fig 4.2 Mark out an appropriate grid for the isolators. NOTE: the grid will be different for 2440x1220mm plywood sheets than it would be for 2400x1200mm sheets.

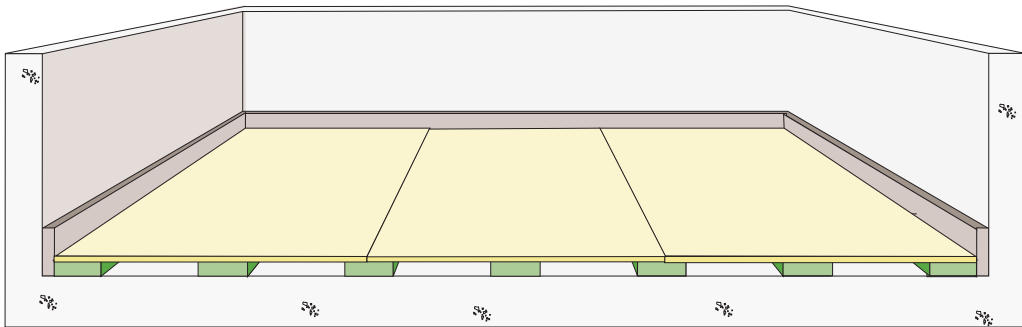

Fig 4.3 Place ply sheets onto Isolators and secure in place.



Installation sequence for a building to house sensitive medical equipment.

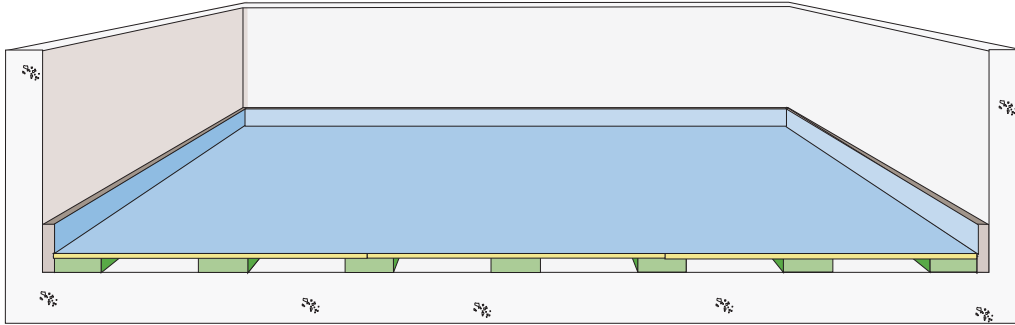

Fig 5.1 Lay DPM onto ply deck with 300mm overlapped and taped joints.

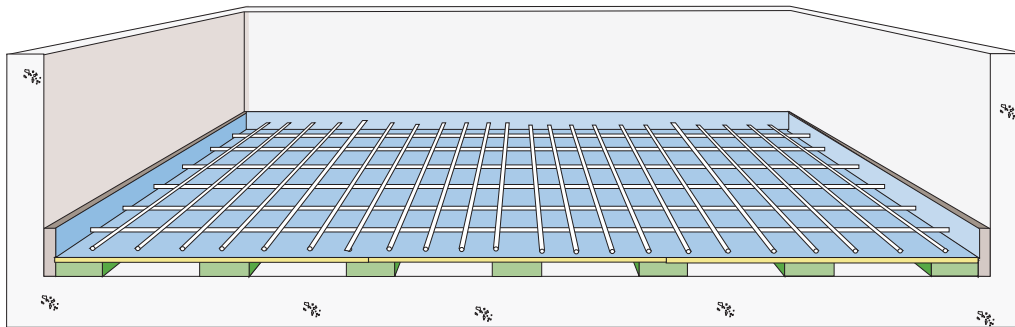

Fig 5.2 Lay reinforcement mesh (if required) onto finished deck to appropriate cover.

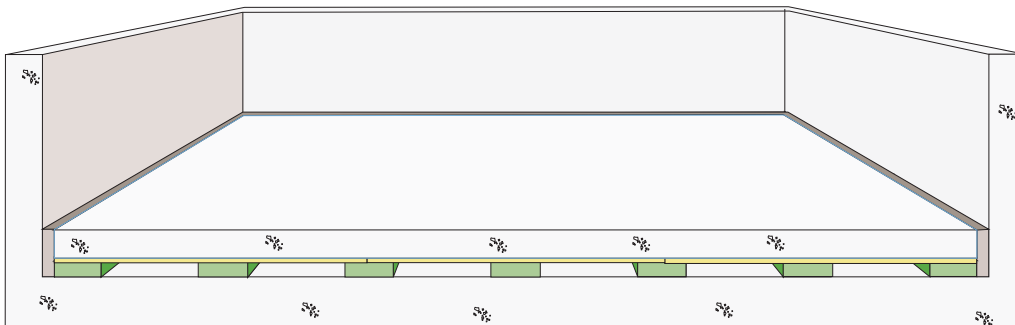

Fig 5.3 Pour floating concrete slab.



Installation sequence for a gym being constructed within a city centre office building.

Fig 6.1 Scenario 1
Simple Layout, uniform load distribution.



Information Required:

- Length
- Width
- Acoustic air gap thickness
- Floating slab thickness
- System natural frequency
- Imposed dead and live loads
- Perimeter detail (fixed lateral Perimeter detail at time of construction) (fixed lateral supports in place or not?)

Fig 6.2 Scenario 2
Complex perimeter shape, heavy equipment placed in certain locations, internal walls placed on floating slab.

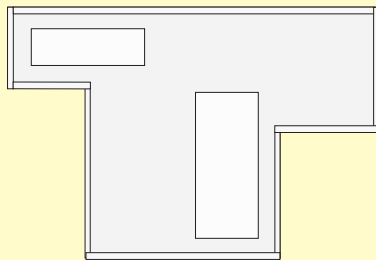

Information Required:

- Layout drawing ideally as .dwg file
- Perimeter length
- Acoustic air gap thickness
- Floating slab thickness
- System natural frequency

Heavy Equipment / Point Loads

- Type of equipment
 - Footprint areas and loadings
 - Fixing type to floating slab (point loads or evenly distributed loads)
- General imposed dead and live loads
Line loads from internal walls as well as depths & offset from edge of floating slab.
Perimeter detail at time of construction (fixed lateral supports in place or not?)

Isomat Dimensions and Capabilities

Floating Slab Thickness (mm)	Design Loads						Isolator Size				Isolator Deflection				Dynamic Natural Frequency	
	DL m ² (kN)	LL m ² (kN)	DL + LL m ² (kN)	No of Isolators per m ²	DL Isolators (kN)	DL + LL Isolators (kN)	Length (mm)	Width (mm)	Thickness (mm)	Material	DL Static Deflection (%)	DL Static Deflection (mm)	DL +LL Static Deflection (%)	DL +LL Static Deflection (mm)	DL Dyn Vert Nat Freq fnd (Hz)	DL +LL Dyn Vert Nat Freq fnd (Hz)
100	2.5	0.0	2.5	2.9	0.9	0.9	75	75	50	IMCR 60-25	5.1%	2.6	5.1%	2.55	12.0	12.8
	2.5	1.0	3.5	2.9	0.9	1.2	75	75	50	IMCR 60-25	5.1%	2.6	7.2%	3.58	12.0	10.8
	2.5	2.0	4.5	2.9	0.9	1.6	75	75	50	IMCR 60-25	5.1%	2.6	9.2%	4.60	12.0	9.5
	2.5	3.0	5.5	2.9	0.9	1.9	75	75	50	IMCR 60-25	5.1%	2.6	11.2%	5.62	12.0	8.6
	2.5	4.0	6.5	2.9	0.9	2.2	75	75	50	IMCR 60-25	5.1%	2.6	13.3%	6.64	12.0	7.9

Standard system performance based on imposed loadings from BS6399 (Loading for buildings - Code of practice for dead and imposed loads)

Where loads or natural frequency requirements vary outside this range please contact Farrat of your local representative for project specific designs.

Standard isolator spacing is 600mm centres however where thinner floating slabs are required or higher imposed loads are predicted then the centre spacing may need to be reduced to 400 or 300mm.

	Thickness (m)	Mass (kg)	Pressure (kN/m ²)
1m ² Concrete	0.100	245.0	2.45
1m ² Plywood	0.015	7.5	0.075
Total	0.115	253	2.5

Suggested centre spacing and isolator quantity calculations as follows:

Ply sheet size 2400x1200: 600mm (approx 2.9/m²) 400mm (approx 6.5/m²) 300mm (approx 11.5/m²)
Ply sheet size 2440x1220: 610mm (approx 2.9/m²) 406mm (approx 6.5/m²) 305mm (approx 11.5/m²)

Where 25mm thick isolators are used, the floating slab will deflect by approximately 4mm under full load. If 50 or 75mm thick isolators are required, then the maximum deflection will be approximately 7.5mm and 12mm respectively.

Walls, columns and point loads: Where point loads are to be applied to the floating floor such as from columns, walls, doors, heavy equipment etc then larger isolators may be required at specific points to ensure an even deflection in the Isomat Isolators to prevent excessive stresses in the floating concrete slab.

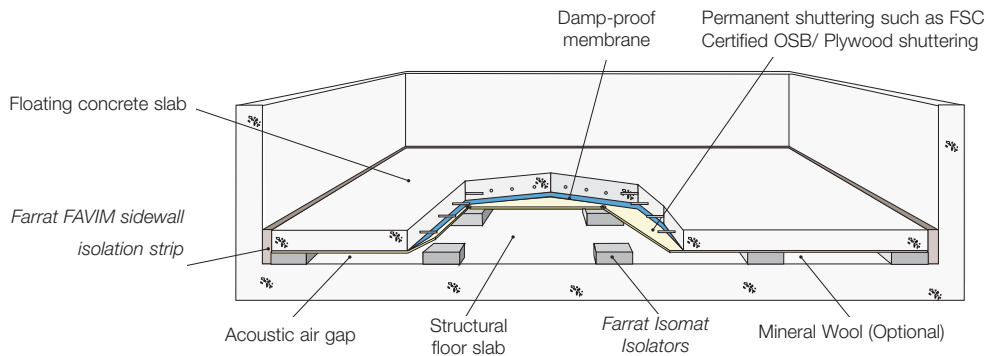

Fig 7.1

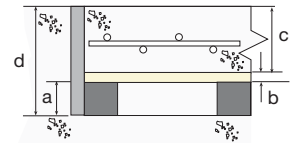

Fig 7.2 a) Isomat Isolators: 50mm
b) Plywood: 15mm
c) Concrete slab: 100mm
d) Overall height: 165mm

FAVIM Sidewall / Lateral Isolation:

FAVIM Sidewall / Lateral Isolation: FAVIM FVM100 is supplied in meter length, 12.5mm thick strips. The height of the strip is calculated by measuring the distance between the structural slab and the top of the floating concrete slab.

Permanent formwork shuttering: The IFFS will work with plywood sheet thickness of 15mm up to 25mm. 12mm ply can be used but extra care must be taken during installation to ensure that it does not sag too much across the isolator centres. Other formwork types can be used, please contact Farrat for approval. NOTE: the thickness of the ply needs to be taken into account when calculating the overall system height as it does not contribute to the acoustic air gap or the strength of the floating concrete slab.

Acoustic mineral wool of varying thicknesses can be installed in the acoustic air gap where the acoustic consultant deems it necessary.

Floating concrete slab: The DPM, concrete and reinforcement grades are to be designed by qualified Structural Engineers but Farrat are happy to assist with this process taking into account the project requirements.

Non concrete variants: The dry part of the IFFS will support any floor type. If a floating concrete slab is not possible then the floors can be constructed from lightweight sandwich constructions using high density acoustic plasterboard and plywood. Such systems are to be designed by qualified acoustic consultants.

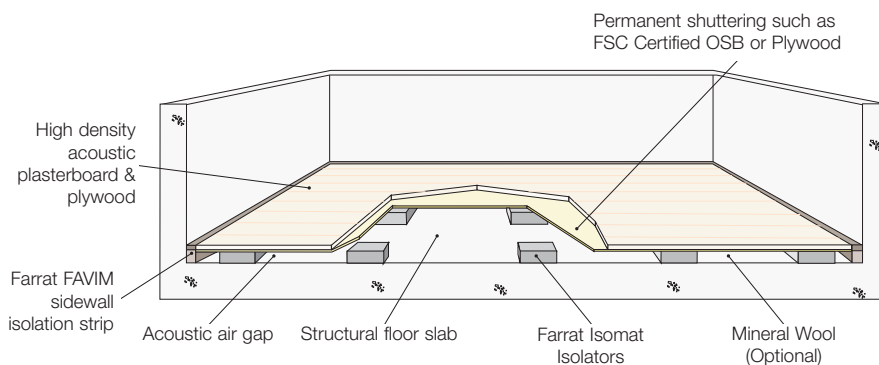

Fig 7.3

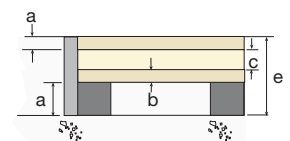

Fig 7.4 a) Isomat Isolators: 50mm
b) Plywood: 19mm
c) Acoustic plasterboard: 30mm
d) Plywood: 19mm
e) Overall height: 118mm

Procurement UK Installations

Within the UK Farrat (www.farrat.com) offer a highly competitive, full turnkey installation service (with or without concrete pour) through our installation partner company AcouStruct Ltd (www.acostruct.com). Farrat will handle the initial inquiry and provide technical and specification support. Farrat then work together with AcouStruct to provide a comprehensive service to the client until the completion of the project. Alternatively it can be supplied as an 'Isolator Kit' (Isomat Isolators, FAVIM sidewall isolation strips and adhesive) with remaining materials and installation labour to be supplied locally. Supervision by Farrat can be arranged.

Worldwide Installations

Where it is not economical or viable to ship all installation materials, Farrat can supply an 'Isolator Kit' (Isomat Isolators, FAVIM sidewall isolation strips and adhesive) with remaining materials and installation labour to be supplied locally. Supervision by Farrat can be arranged. Farrat is actively building up a database of **agents and quality approved installation partners**. Please contact Farrat for information on local agents (or if you wish to become a local agent) as well as technical information and quotations.

CAT 10.09: Isomat Isolated Foundations
High load, shock and vibration isolation



94m long newspaper printing press on Isomat Isolated Foundation.



Left: Test rig on FSL coil spring isolated foundation.

Right: Rhodes 350t power press on Isomat isolated foundation.

Isomat Isolated Foundations

Isomat Floating Floors are based on similar principles as Isomat Isolated Foundations which are used predominantly for industrial equipment. Farrat boasts significant experience in the specification and supply of hundreds of these specialised systems all over the world.

The 'decoupled' inertia blocks play the following, important roles in vibration isolation:

- **Increases mass, which reduces transmitted machine vibrations through mass damping (doubling the mass will halve the transmitted vibration) and improves machine stability by lowering the centre of gravity.**
- **Confine vibration within block rather than transmitting it into the ground.**
- **Provide machine frame stiffness.**
- **Distribute static and dynamic loads over a greater ground area.**
- **Minimise changes in level due to alterations in static load distribution.**

Farrat Isolated Foundation Systems can be formed from: Isomat, VIDAM, Favim or Coil Spring and Visco-elastic Dampers. If provided with the nature of the requirement or the expected requirement, Farrat can provide technical / design advice and develop appropriate solutions including full specifications, predicted natural frequencies, damping ratios, layout drawings and installation instructions etc. If necessary, site installation or supervision can be provided.

Please contact Farrat for more information and technical specification assistance.

Isomat Isolated Foundations

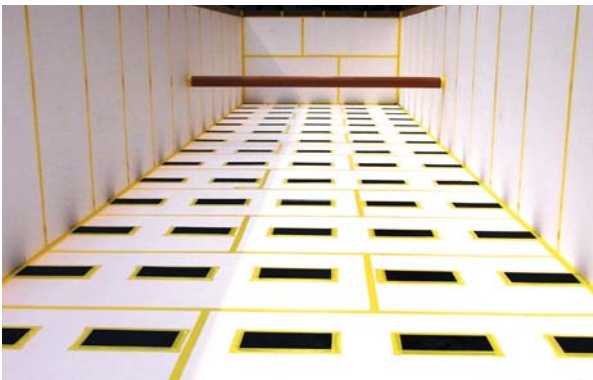

Above: Isomat isolated foundation for a large paper roll grinder during installation.

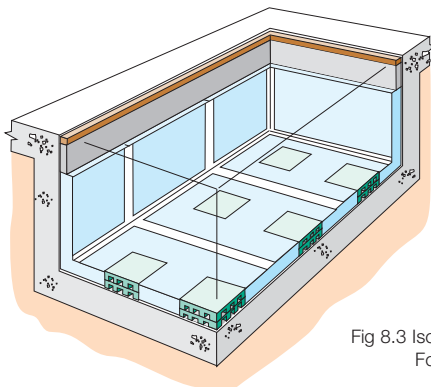

Fig 8.3 Isomat Isolated Foundation.

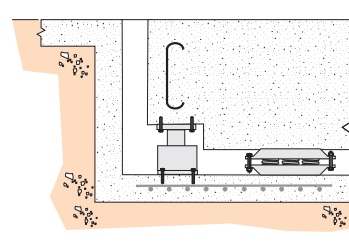
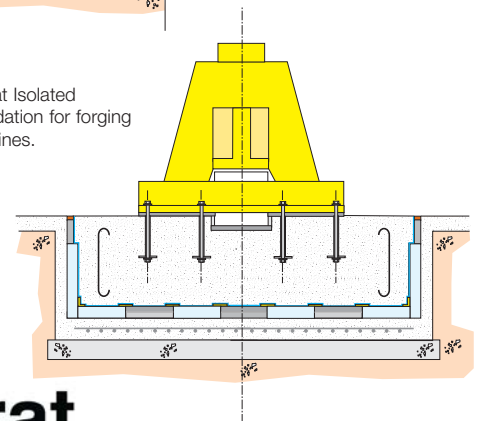

Fig 8.1 FSL spring and FV damper low frequency isolated foundation.

Fig 8.2 Isomat Isolated Foundation for forging machines.



Farrat Isolevel Ltd. Balmoral Road, Altrincham,
 Cheshire WA15 8HJ. England GB
 Tel: +44 (0) 161 924 1600 Fax: +44 (0) 161 924 1616
 email: sales@farrat.com www.farrat.com

www.farrat.com