

**Thermal Performance****Question 1**

What is the difference between the materials?  
Which one should I choose for a particular connection?

**Answer**

**TBG300** is a very high strength (up to 300N/mm<sup>2</sup> (MPa) = 300,000kN/m<sup>2</sup>) non-compressible material made from glass reinforced polymer resin.

**TBN100** (formerly TBN260) is a Nylon based material which will withstand medium loadings (up to 96N/mm<sup>2</sup> (MPa) = 96,000kN/m<sup>2</sup>). TBN100 will compress by approximately 10% at its ultimate compressive load of 96N/mm<sup>2</sup>.

The primary driver for choice of material is the compressive and shear loads being applied through the connection. Based on the loading characteristics of the materials it is left to the structural engineer to decide which material is most suitable.

**Question 2**

What thermal conductivity (U-value) performance will such a connection provide?

**Answer**

The thermal conductivity of **TBG300** is 0.18 W/m.K and for **TBN100** is 0.29W/m.K, this compares to around 54W/m.K for steel. The thicker the Thermal Break pad, the better the thermal isolation. U-value is calculated by the customer according to the building design, connection type, size and Thermal Break material.

**Question 3**

Will there not be some thermal transfer through the connection bolts?

**Answer**

Yes that is the case although from a 'whole building' perspective the actual amount of thermal transfer will be minimal because of the contact relative area. The Farrat method of incorporating a thermal break into a structural element is designed to provide an economical balance between structural integrity and thermal insulation. The bolts can be thermally isolated using Farrat **AWTB** Washers & Bushes.

Using stainless steel bolts can further improve a connection's performance as stainless steel is a low thermal conductor (16 W/m.K) as opposed to normal steel (54 W/m.K). This however creates a steel to stainless steel interface which must be protected against bi-metallic corrosion of the steel components. Stainless **AWTB** Washers & Bushes can be used to prevent bi-metallic corrosion as well as reduce the amount of thermal transfer.

**Question 4**

Can I thermally isolate the bolts through the connection?

**Answer**

Yes, Farrat offers high strength neoprene washers & bushes (**AWTB**) which can be used to separate the bolt from the connection whilst maintaining the full structural integrity of the connection. More information on washers and bushes is available from Farrat.

**Question 5**

How can I achieve the best level of thermal insulation with such a connection?

**Answer**

- Use the thickest thermal break possible (25mm for both **TBG300** & **TBN100**)
- Use stainless steel connection bolts to thermally insulate the bolt through connections using Farrat **AWTB** washers & bushes.
- Reduce the amount of material in the connection. The best insulator is air so, where it is structurally feasible, unnecessary material can be cut out of the Farrat thermal break connection plates leaving a clear air gap between the connecting pieces.

See page 2 of the datasheet for methods of achieving this. It is left to the structural engineer to design such connections based on the characteristics of Farrat Thermal Break materials.

**Question 6**

What thickness of material are available / most popular?

**Answer**

The standard material thicknesses are:

**TBG300:** 6, 10, 12, 15, 20, 25mm

**TBN100:** 10, 12, 16, 25mm

Farrat always aims to hold high stock levels of 12 & 25mm thickness. 10 & 16mm thicknesses are usually kept in stock but in lower quantities than 12 & 25mm.

**Question 7**

Where in the building should I fit the thermal break connection plate inside/outside external render/insulation?

**Answer**

Ideally the thermal break should be located within the building envelope. If it is located outside the building there is a risk of cold bridging from the exposed elements between the thermal break connection and the building.

**Supply & Installation**

**Question 8**

How do I order Farrat Thermal Break connection pads?

**Answer**

In order to provide a comprehensive quotation we ask our customers to email drawings (ideally in .drg files or alternatively as a PDF of the drawing) of the required pads showing type of material, quantities required, dimensions and details of any holes or slots etc to be cut to: **sales@farrat.com**

**Question 9**

What is the expected lead time?

**Answer**

Since most items are bespoke to a customer's drawings typical lead times are 1 to 3 weeks depending on the complexity and volume of an order however we will always endeavour to deliver as quickly as possible to meet the customer's requirements. Lead times are dependent on the delivery and accuracy of the customer's pad drawings.

**Question 10**

Do Farrat supply standard pad sizes?

**Answer**

All pads are made to order. They can be cut to any size (within the constraints of the full sheet sizes) with holes of any diameter cut anywhere on the pads according to the customer's drawings. Where strips or pads are required that are longer than the full sheet sizes, pads can be combined to make up the full requirement. They are delivered with clear labelling for easy identification on site.

**Question 11**

Can they be supplied in sheet form instead of ready cut pads?

**Answer**

**TBG300** can only be supplied as custom pads as special equipment is required to cut the material.

**TBN100** it is recommended that Farrat supply custom pads but we can also deliver this material in sheet form for the customer to cut and drill as appropriate.

**Question 12**

Are there any special considerations for handling on site?

**Answer**

Both materials should be treated with reasonable care during handling or installation. **TBG300** should not be subjected to impacts. (Safety datasheets available on request)

**Question 13**

Any special safety considerations?

**Answer**

Farrat recommends using suitable PPE as per normal site conditions when installing these items and whilst handling **TBG300** we recommend wearing gloves. Safety datasheets are available on request or are downloadable from **www.farrat.com**.

**www.farrat.com**

**Technical Specification**

**Question 14**

Are there any special considerations for connection designs?

**Answer**

When designing moment/cantilever connections please bear in mind that both **TBG300 & TBN100** have a low surface coefficient of friction meaning the interface will have a lower slip performance than a steel washer connection interface. It may also be necessary to consider the small increase in additional bending moment that will occur in the bolts due to the separation of the steelwork flanges when the thermal break connection plate is installed.

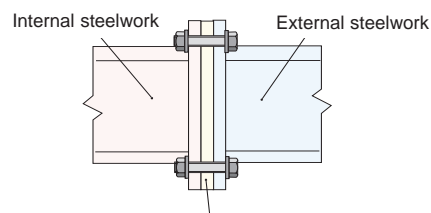

Fig 1 TBG/TBN Plate

**Question 15**

Are the maximum loading pressures and shear strengths ultimate or working values?

**Answer**

All loading figures noted are maximum working (non factored) values and should not be exceeded.

**Question 16**

Can the materials be grouted in place?

**Answer**

Both materials can be wet grouted on site although this may affect the thermal insulation performance of the connection.

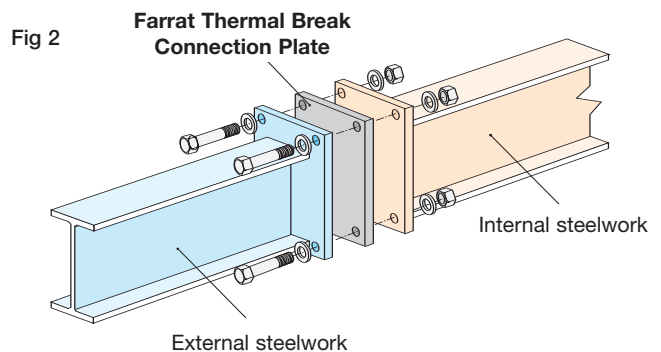

Fig 2

**Farrat.com**

Farrat Isolevel Ltd. Balmoral Road, Altrincham,  
Cheshire WA15 8HJ. England GB  
Tel: +44 (0) 161 924 1600  
Fax: +44 (0) 161 924 1616 email: sales@farrat.com

