

Fig 23.1

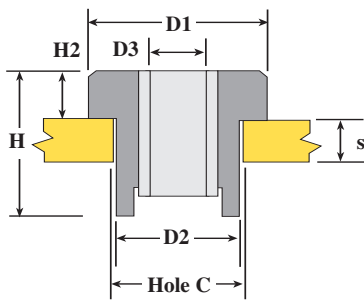
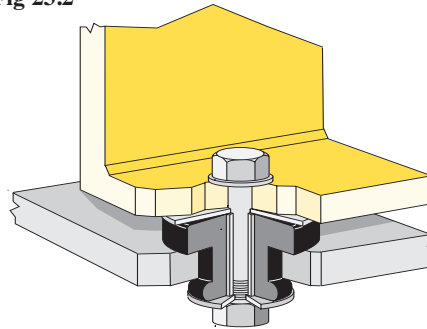

Fig 23.2



STC Farrat Code	Rubber NR Irhd Sh.A	Dimensions mm						
		D1	D2	D3	H1	s	H2	Hole C
STC 2845	45	28	20.6	10	17.5	8	5.6	21
STC 2860	60	28	20.6	10	17.5	8	5.6	21
STC 4445	45	45	31.5	13	25.4	10	10.4	32
STC 4445	60	45	31.5	13	25.4	10	10.4	32
STC 5060	60	50	34.3	13	35	16	13.5	35
STC 5075	75	50	34.3	13	35	16	13.5	35
STC 6360	60	64	41.1	16	45	19	15.7	42
STC 6375	75	64	41.1	16	45	19	15.7	42
STC 9560	60	95	60	20	60	23	25	57
STC 9575	75	95	60	20	60	23	25	57

Farrat Code	Old Code	Rubber NR Irhd Sh.A	Load capacities				Stock
			Max. Load N	Defl. At Max. Load mm	Spring Rate N/mm		
STC 2845	539887-45	45	350	0.7	500	1	
STC 2860	539887-60	60	500	0.7	715	2	
STC 4445	539190-45	45	750	1.2	625	1	
STC 4460	539190-60	60	1000	1.2	833	1	
STC 5060	538886-60	60	1500	1.2	1250	1	
STC 5075	538886-75	75	3300	1.2	2750	1	
STC 6360	539191-60	60	2500	2	1250	1	
STC 6375	539191-75	75	5000	2	2500	1	
STC 9560	-	60	5000	4	1250	1	
STC 9575	-	75	10000	4	2500	3	

Stock Availability (subject to change)

- 1) Generally ex stock
- 2) 2-3 days
- 3) Subject to quotation

Order Example: **STC 5060**

STC is a vibration, shock and noise isolator which has been designed for the secure support of equipment installed in any direction.

Especially suitable for rugged applications, these isolators are used for the cabins and engines of off-road and agricultural vehicles, for motors, power packs and electrical equipment etc.

Manufactured as a one piece cylindrical Natural Rubber NR moulding for maximum resilience and isolation performance, the STC has a centrally bonded thick wall steel tube

Generally the top steel washer, lower rebound steel washer and equipment fixing screw are not supplied by Farrat, except against special orders.

Installation is very simple. The STC is fitted to a supporting frame or chassis by inserting it into a hole having rounded edges and a smooth bore. The fixing screw is passed through the equipment foot and top washer, through the steel tube and then tightened onto the lower washer with a nut.

Farrat reserve the right to alter a specification if it is in the interest of product improvement.